

REV
SH
9313B
DWG NO

REVISIONS			
REV	DESCRIPTION	DATE	APPROVED

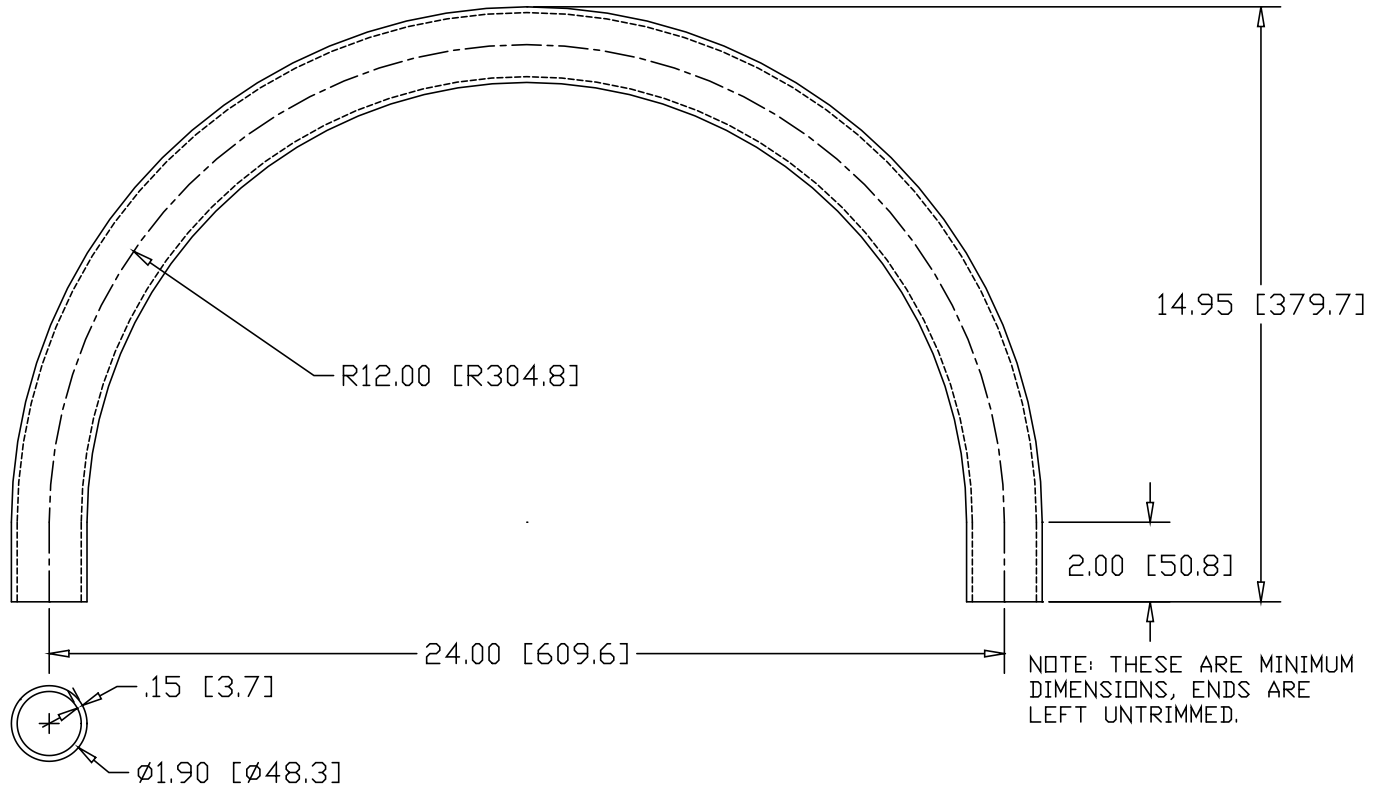

INCHES [MILLIMETERS]

ALTERNATE MATERIAL	PART NUMBER
1-1/2" SCH 40 (6063) ALUMINUM PIPE	9327B
1-1/2" SCH 40 (304) STAINLESS STEEL PIPE	9341B

PART NAME 1-1/2" PIPE SIZE 180° ELL X 11.05" I.R. W/ (2) 2" TANGENTS			
MATERIAL 1-1/2" SCH 40 A53 STEEL PIPE			
DATE 8/16/01	WAGNER	R & B WAGNER, INC.	
DRAWN BY JAH			
FINISH MILL			
SIZE A	WEIGHT 9.37 LBS	PART NUMBER 9313B	REV