

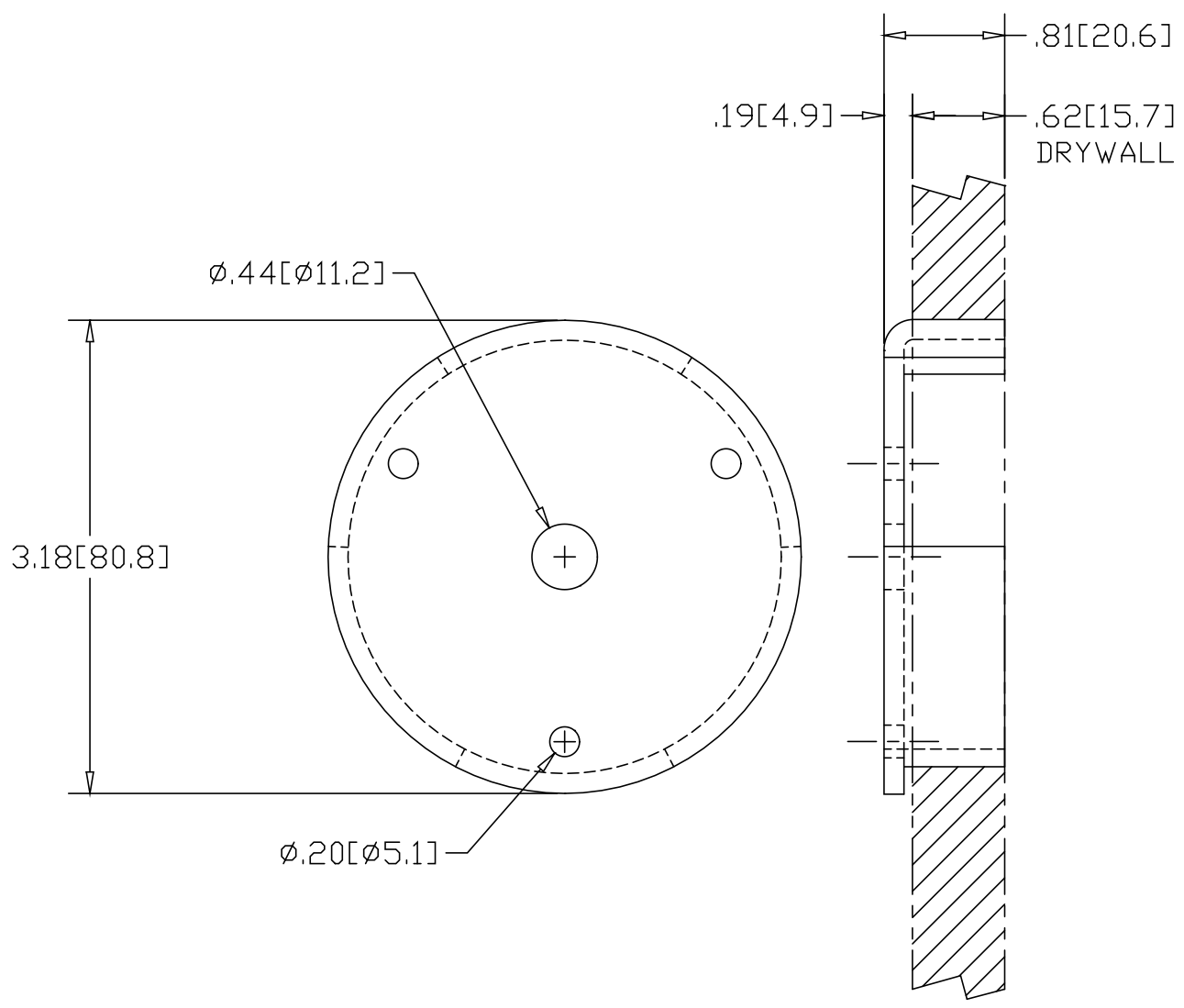

REV
SH
1721
DWG NO

REVISIONS			
REV	DESCRIPTION	DATE	APPROVED



*USE WITH HEAVY CAST "U" STYLE HANDRAIL BRACKETS WITH (1) CENTER HOLE

ALTERNATE MATERIAL	PART NUMBER
.125 (3003) ALUMINUM ASTM B209	1753A

PART NAME UNIVERSAL PLASTER FILLER FOR 5/8" DRYWALL			
MATERIAL 10 GA. HRP&D STEEL ASTM A569			
DATE 11/18/98		THE WAGNER COMPANIES R & B WAGNER, INC. AND J. G. BRAUN CO.	
DRAWN BY RJF			
FINISH MILL			
SIZE A	WEIGHT .4 LBS	PART NUMBER 1721	REV