

REV  
SH  
9215  
DWG NO

REVISIONS			
REV	DESCRIPTION	DATE	APPROVED

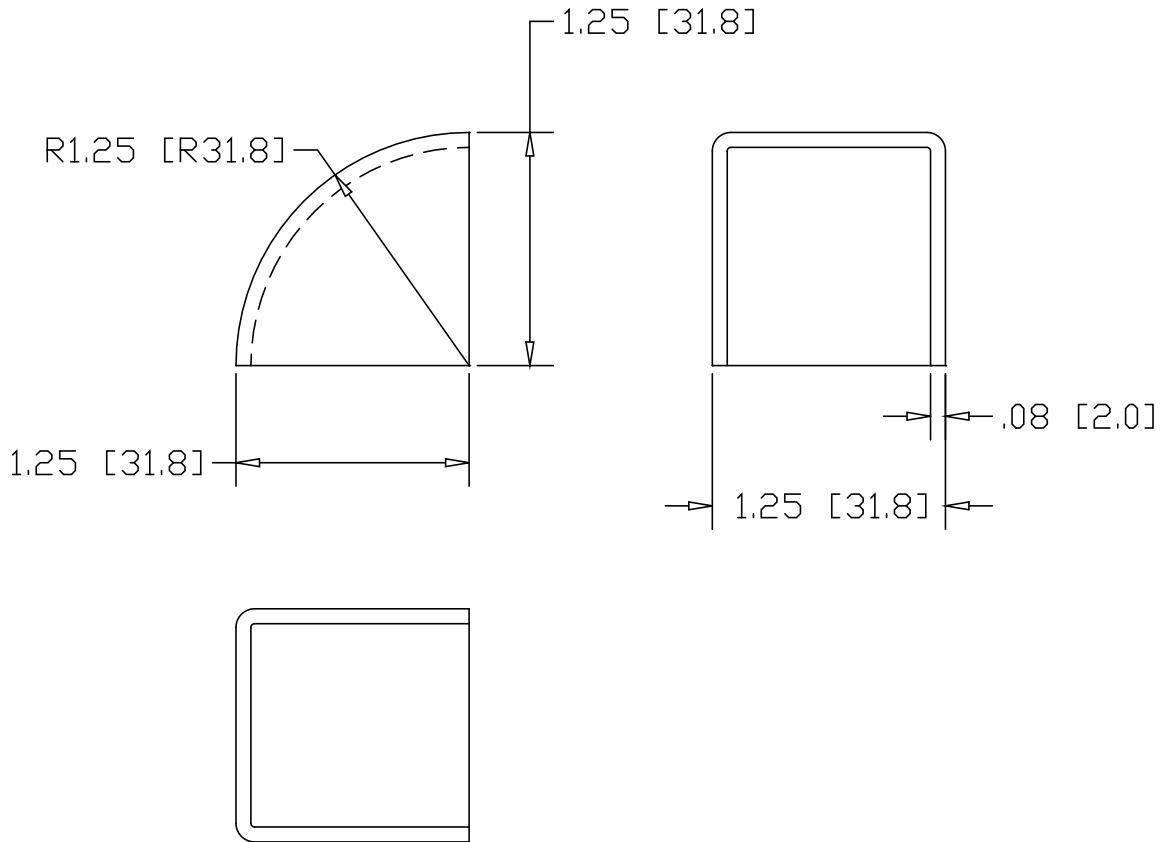

INCHES [MILLIMETERS]

ALTERNATE MATERIAL	PART NUMBER
.080 (3003) ALUMINUM ASTM B209	9216
14 GA. (304) STAINLESS STEEL	9217
.083 (260) BRASS	9218

PART NAME		1-1/4" SQUARE TUBE CORNER	
MATERIAL		14 GA. HRP&D STEEL ASTM A569	
DATE	8/26/96		THE WAGNER COMPANIES R & B WAGNER, INC. AND J. G. BRAUN CO.
DRAWN BY	RJF		
FINISH	MILL		
SIZE	A	WEIGHT	.09 LBS
PART NUMBER		9215	
REV			