

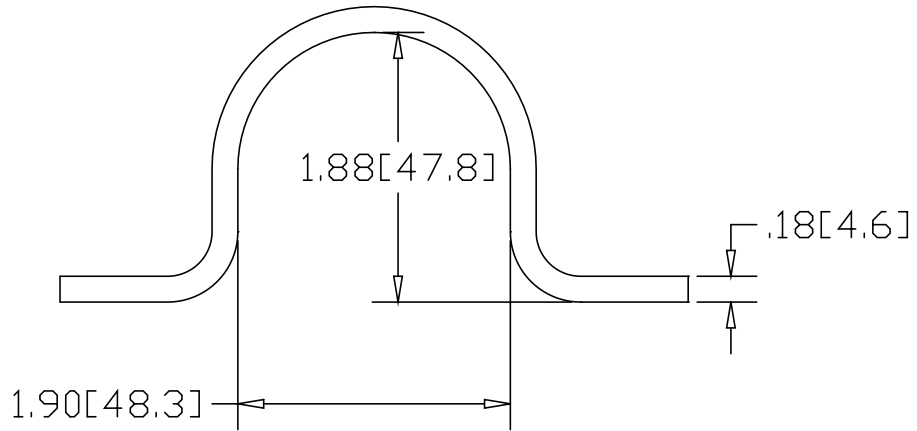

REV
SH
3684-NH
DWG NO

REVISIONS			
REV	DESCRIPTION	DATE	APPROVED

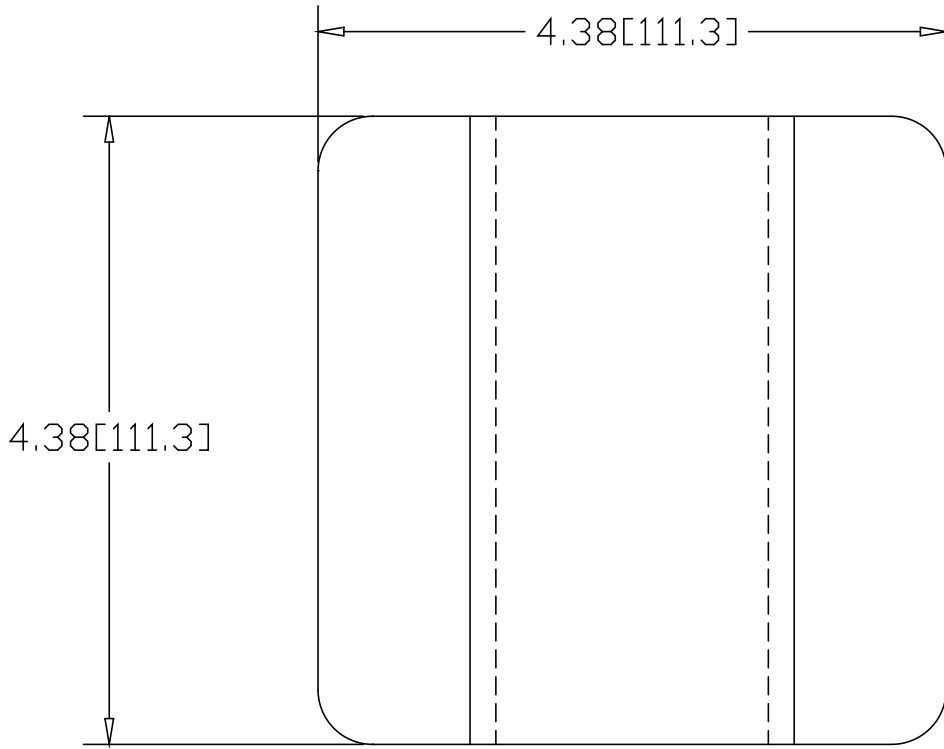

INCHES [MILLIMETERS]

ALTERNATE MATERIAL	PART NUMBER
.190 (3003) ALUMINUM ASTM B209	3685-NH
7 GA. (304) STAINLESS STEEL ASTM A240	3684-SS-NH

PART NAME		1-1/2" PIPE X 4.38" WIDE U-BRACKET	
MATERIAL		7 GA. HRP&D STEEL ASTM A569	
DATE	02/11/00	 THE WAGNER COMPANIES R & B WAGNER, INC. AND J. G. BRAUN CO.	
DRAWN BY	RJF		
FINISH	MILL		
SIZE	WEIGHT	PART NUMBER	REV
A	1.41 LBS	3684-NH	