

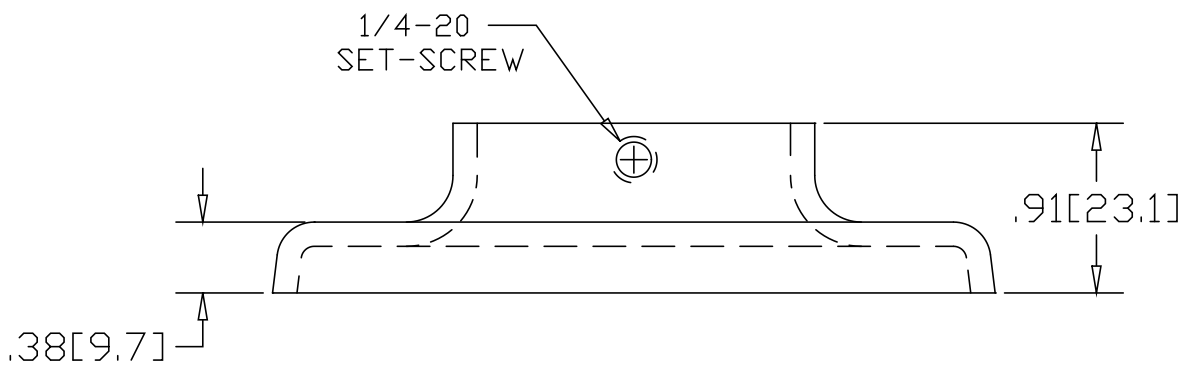

REV
SH
1429
DWG NO

REVISIONS			
REV	DESCRIPTION	DATE	APPROVED

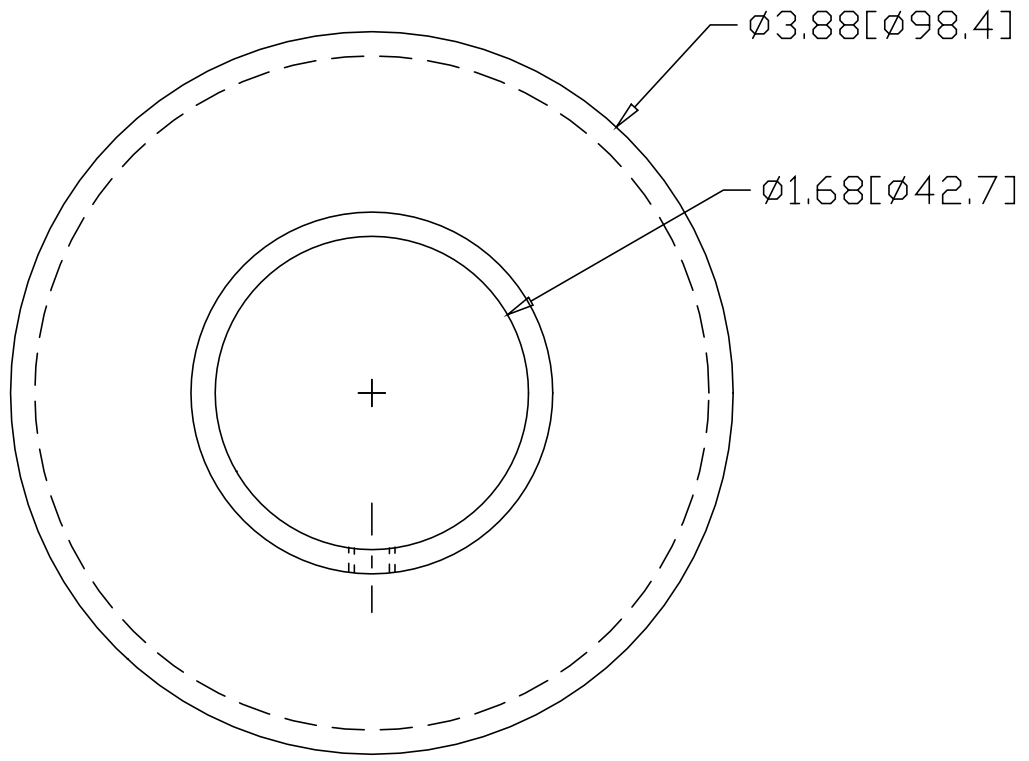

INCHES [MILLIMETERS]

ALTERNATE MATERIAL	PART NUMBER
.125 (3003) ALUMINUM ASTM B209	1469
10 GA. (304) STAINLESS STEEL ASTM A240	1529

PART NAME 1-1/4" PIPE HEAVY BASE FLANGE WITH SET-SCREW			
MATERIAL 10 GA. HRP&D STEEL ASTM A569			
DATE 9/13/94	 R & B WAGNER, INC.		
DRAWN BY RJF			
FINISH MILL	SIZE A	WEIGHT .50 LBS	PART NUMBER 1429
			REV