

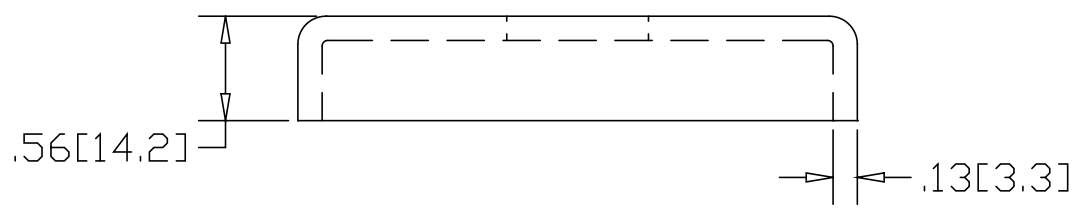

REV  
SH  
DWG NO 8701

REVISIONS			
REV	DESCRIPTION	DATE	APPROVED

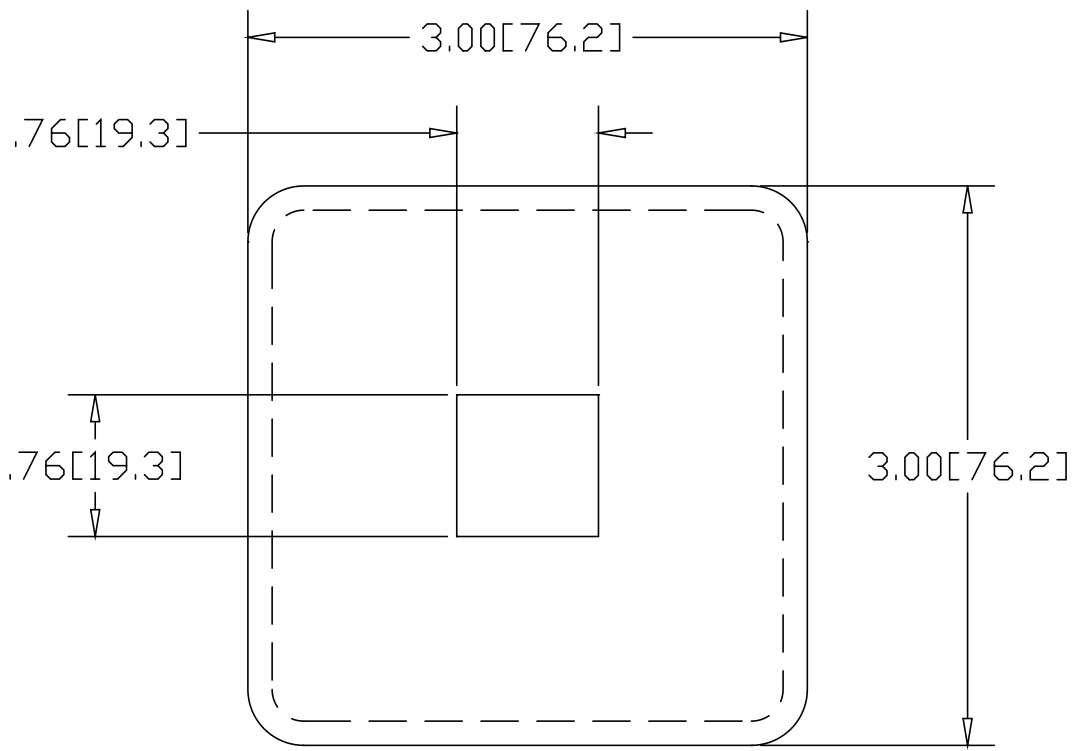

INCHES [MILLIMETERS]

ALTERNATE MATERIAL	PART NUMBER
.125 (3003) ALUMINUM ASTM B209	8771
10 GA. (304) STAINLESS STEEL ASTM A240	8841

PART NAME		.75" SQUARE TUBE HFB FLANGE					
MATERIAL		10 GA. HRP&O STEEL ASTM A569					
DATE	6/20/95	 <b>R &amp; B WAGNER, INC.</b>					
DRAWN BY	RJF						
FINISH	MILL						
SIZE	A	WEIGHT	.42 LBS	PART NUMBER	8701	REV	