

REV
SH
DWG NO 4916T

REVISIONS			
REV	DESCRIPTION	DATE	APPROVED

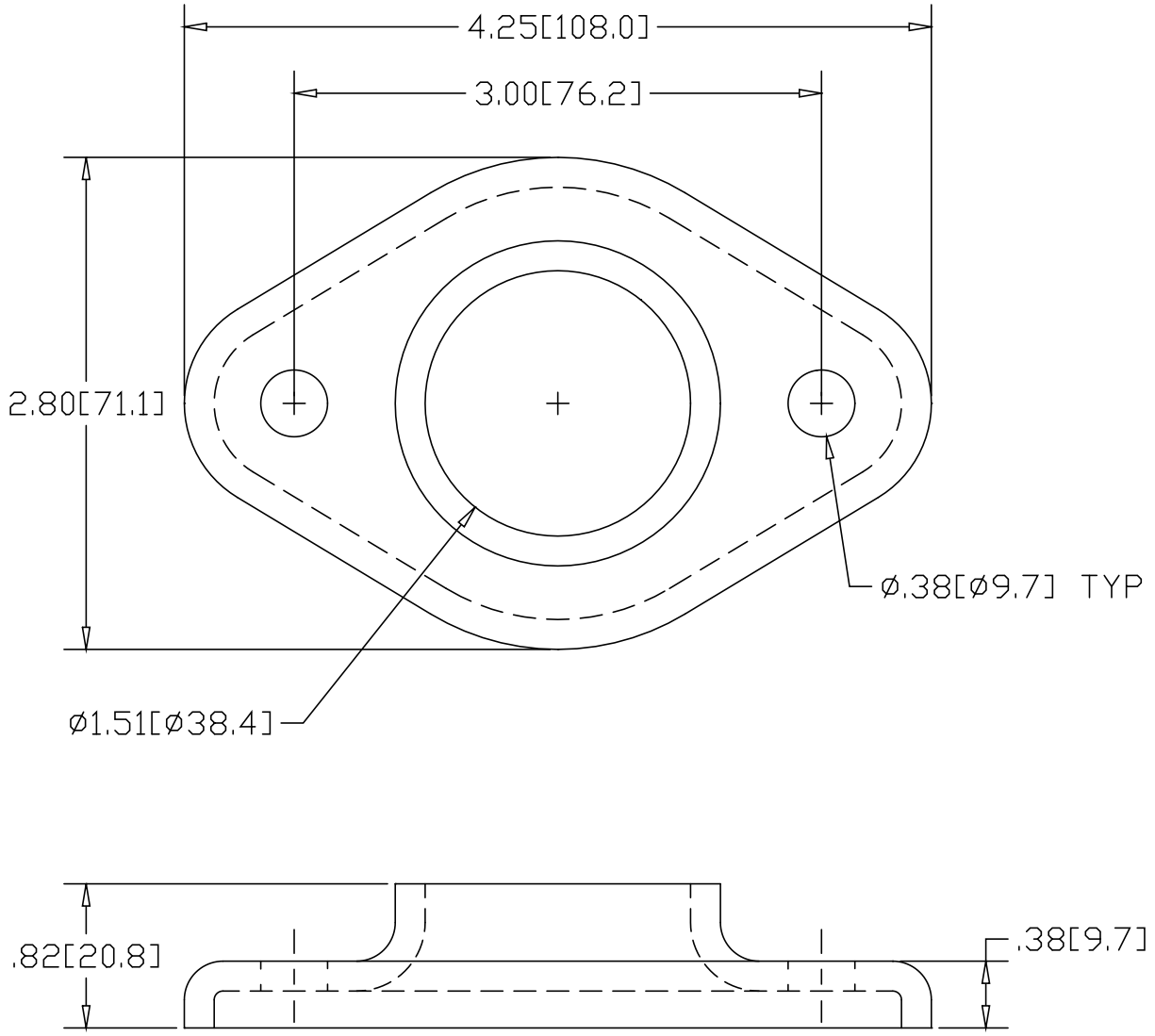

INCHES [MILLIMETERS]

* USE WITH ANCHOR PLATE
 #4914 IN STEEL
 #4944 IN ALUMINUM
 #4974 IN STAINLESS

ALTERNATE MATERIAL	PART NUMBER
.190 (3003) ALUMINUM ASTM B209	4946T
7 GA. (304) STAINLESS STEEL ASTM A240	4976T

PART NAME 1-1/2" O.D. TUBE TAPERED HEAVY BASE FLANGE W/(2) HOLES			
MATERIAL 7 GA. HRP&D STEEL ASTM A569			
DATE 5/22/95	 R & B WAGNER, INC.		
DRAWN BY RJF			
FINISH MILL	SIZE A	WEIGHT .41 LBS	PART NUMBER 4916T
			REV