

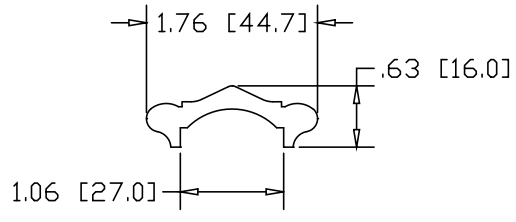

REV  
SH  
H1248AAL  
DWG NO

REVISIONS			
REV	DESCRIPTION	DATE	APPROVED

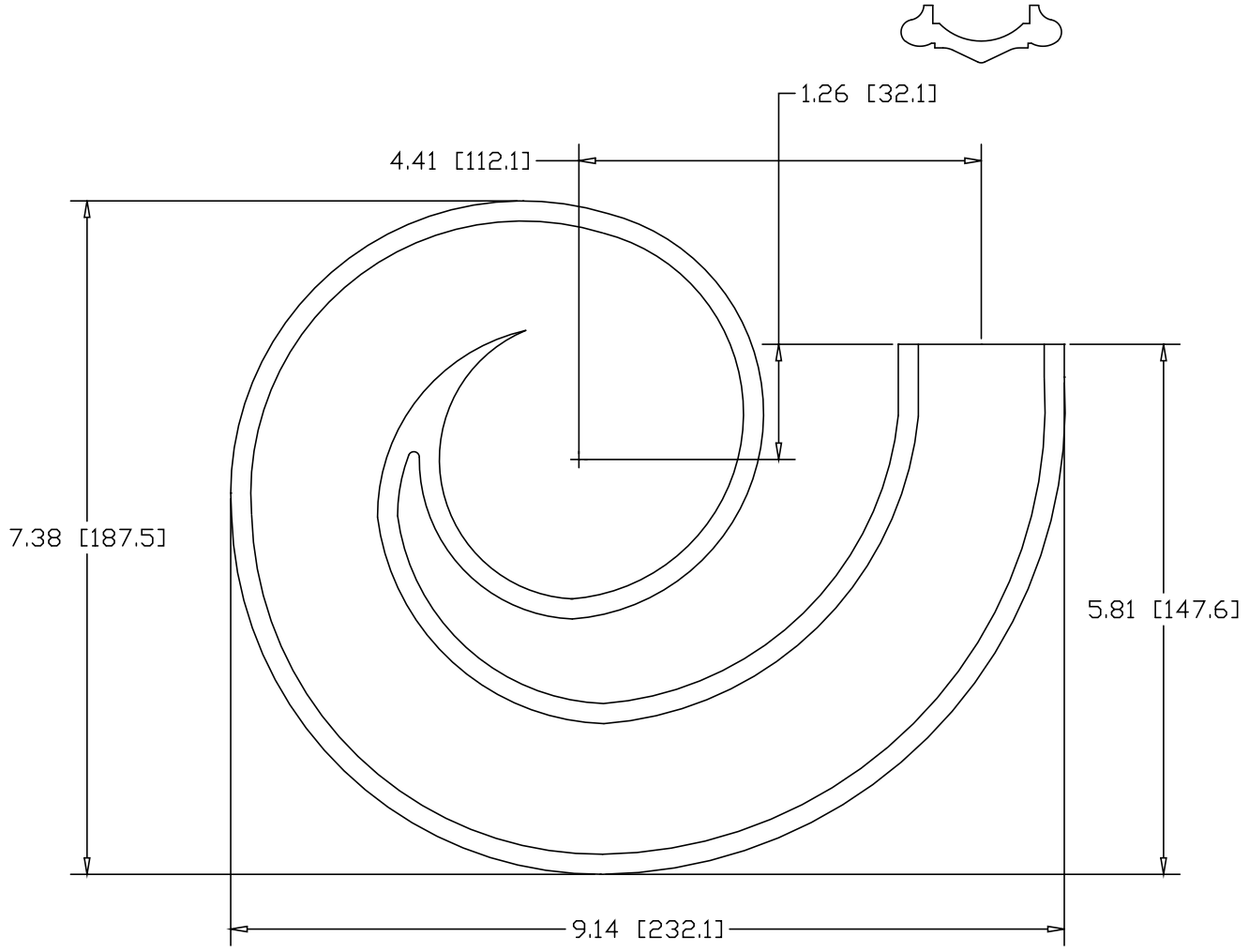

INCHES [MILLIMETERS]

PART NAME		INTERMEDIATE LATERAL SCROLL, LEFT HAND					
MATERIAL		MALLEABLE IRON ASTM A47					
DATE	8/22/03	 <b>THE WAGNER COMPANIES</b> R & B WAGNER, INC. AND J. G. BRAUN CO.					
DRAWN BY	RJF						
FINISH	AS-CAST						
SIZE	A	WEIGHT	2.68 LBS	PART NUMBER	H1248AAL	REV	