

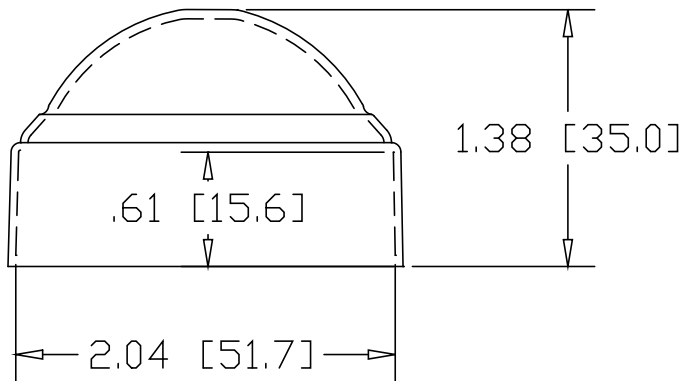

REV
SH
5100
DWG NO

REVISIONS			
REV	DESCRIPTION	DATE	APPROVED
A	REDRAWN	3/30/09	DGP

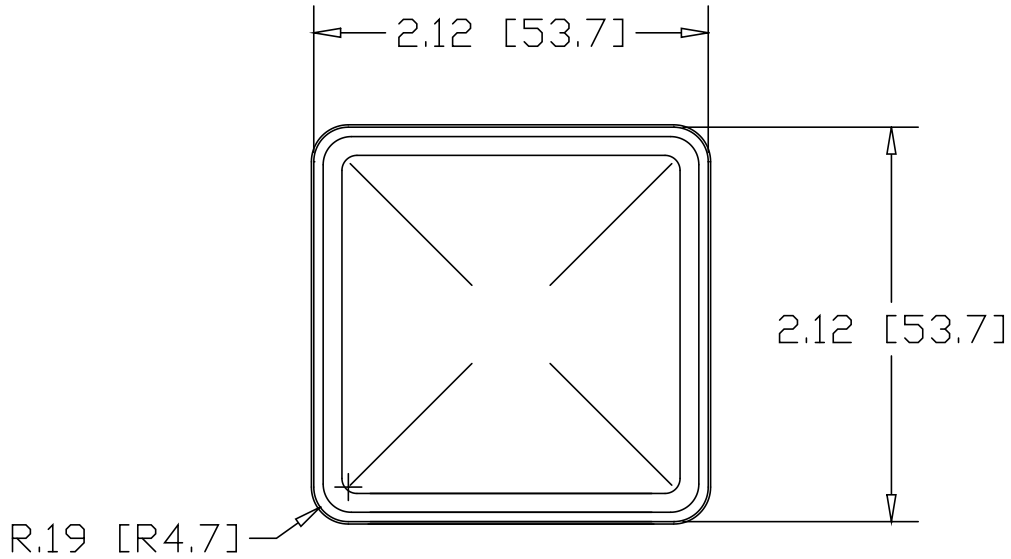

INCHES [MILLIMETERS]

PART NAME		2.00" SQUARE NEWEL POST CAP					
MATERIAL		18 GAUGE CR STEEL ASTM A366					
DATE	6/1/94		THE WAGNER COMPANIES R & B WAGNER, INC. AND J. G. BRAUN CO.				
DRAWN BY	RJF						
FINISH	MILL						
SIZE	A	WEIGHT	.126 LBS	PART NUMBER	5100	REV	A