

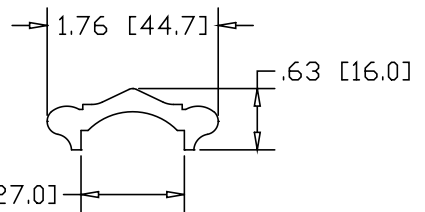

REV
SH
DWG NO H1248AL

REVISIONS			
REV	DESCRIPTION	DATE	APPROVED

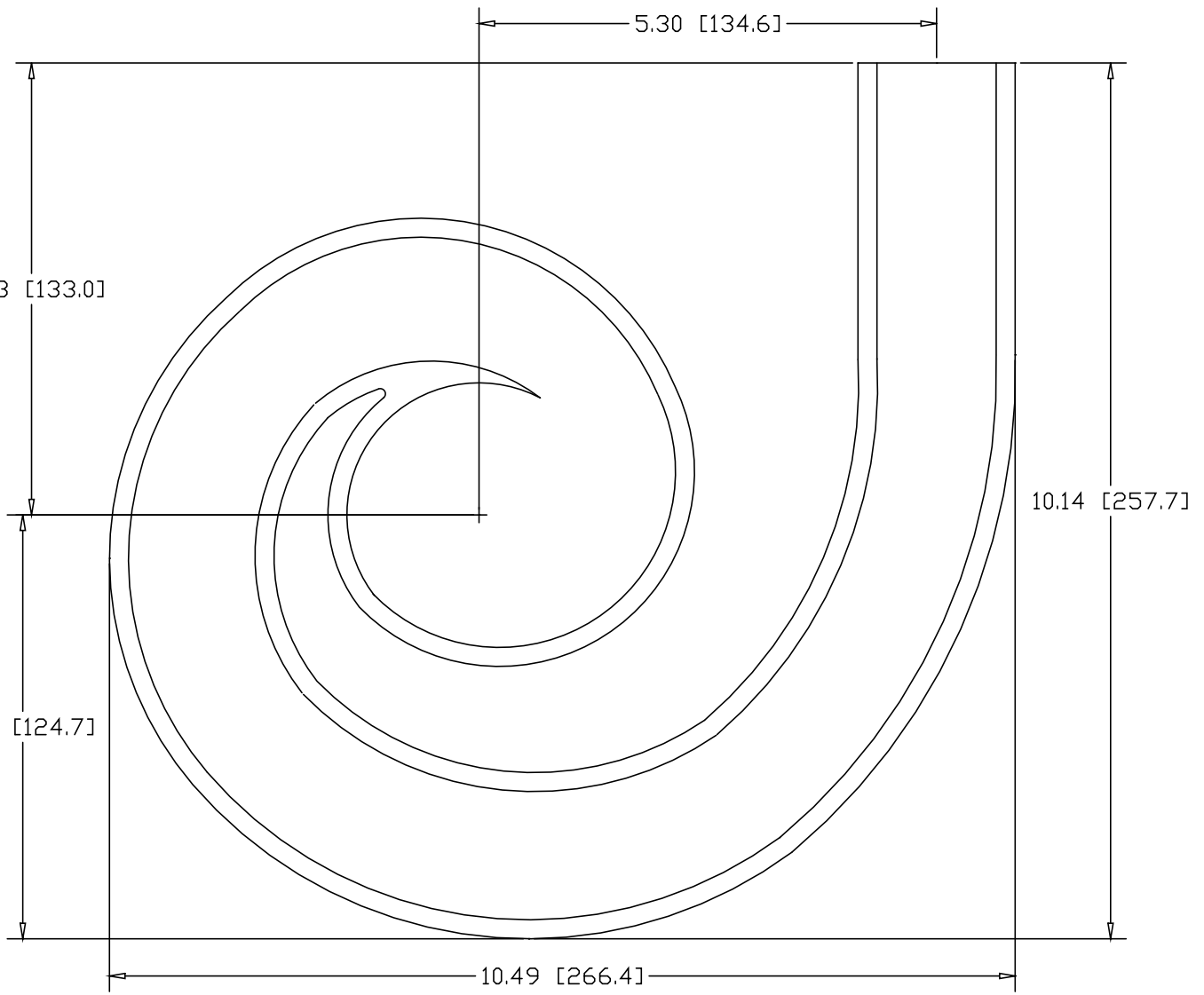

INCHES [MILLIMETERS]

PART NAME				SENIOR LATERAL SCROLL, LEFT HAND			
MATERIAL				MALLEABLE IRON ASTM A47			
DATE		01/29/09		 THE WAGNER COMPANIES R & B WAGNER, INC. AND J. G. BRAUN CO.			
DRAWN BY		RJF					
FINISH		AS-CAST					
SIZE	WEIGHT	PART NUMBER		REV			
A	3.64 LBS	H1248AL					