

REV
SH
1602
DWG NO

REVISIONS			
REV	DESCRIPTION	DATE	APPROVED

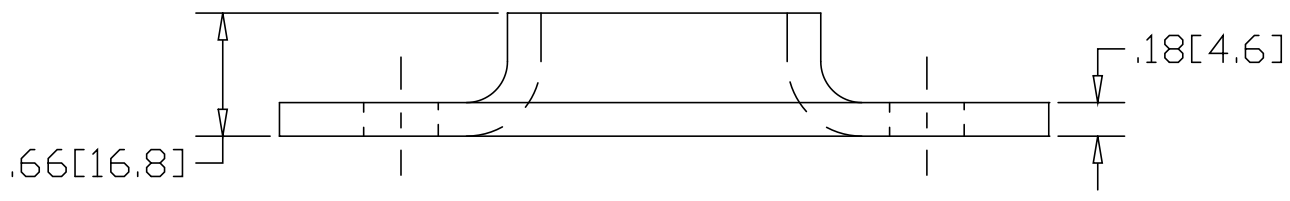
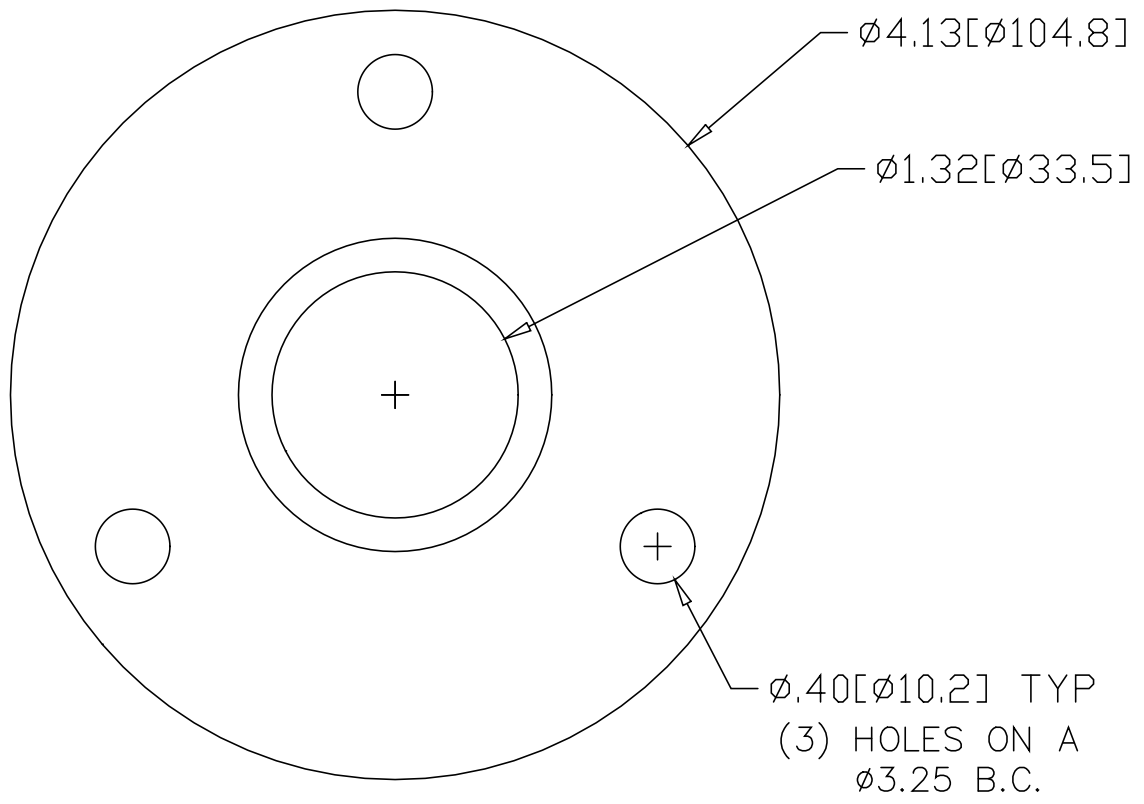

INCHES [MILLIMETERS]

*USE WITH ANCHOR PLATE
 #B1608 IN STEEL
 #B1658 IN ALUMINUM

ALTERNATE MATERIAL	PART NUMBER
3/16" (3003) ALUMINUM ASTM B-209	1652

PART NAME 1" PIPE SIZE EXTRA HEAVY FLANGE W/(3) HOLES			
MATERIAL 3/16" HRP&O STEEL ASTM A-569			
DATE 2/23/99	 R & B WAGNER, INC.		
DRAWN BY RJF			
FINISH MILL	SIZE A	WEIGHT .6 LBS	PART NUMBER 1602
			REV