

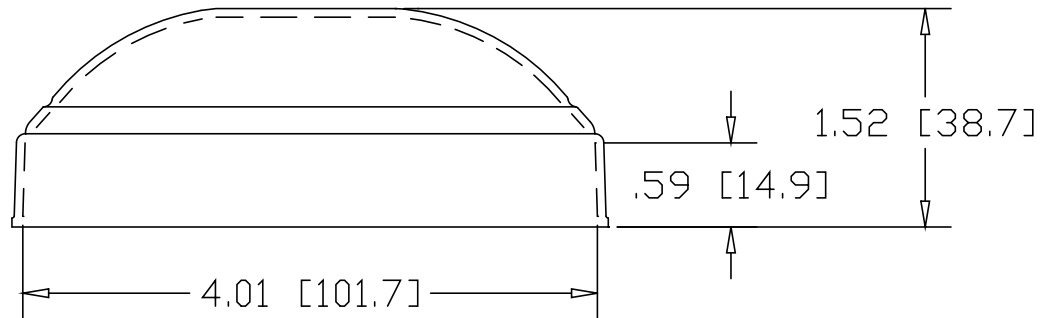

REV  
A  
SH  
5120  
DWG NO

REVISIONS			
REV	DESCRIPTION	DATE	APPROVED
A	1.52 WAS 1.59	08/02/05	RJF

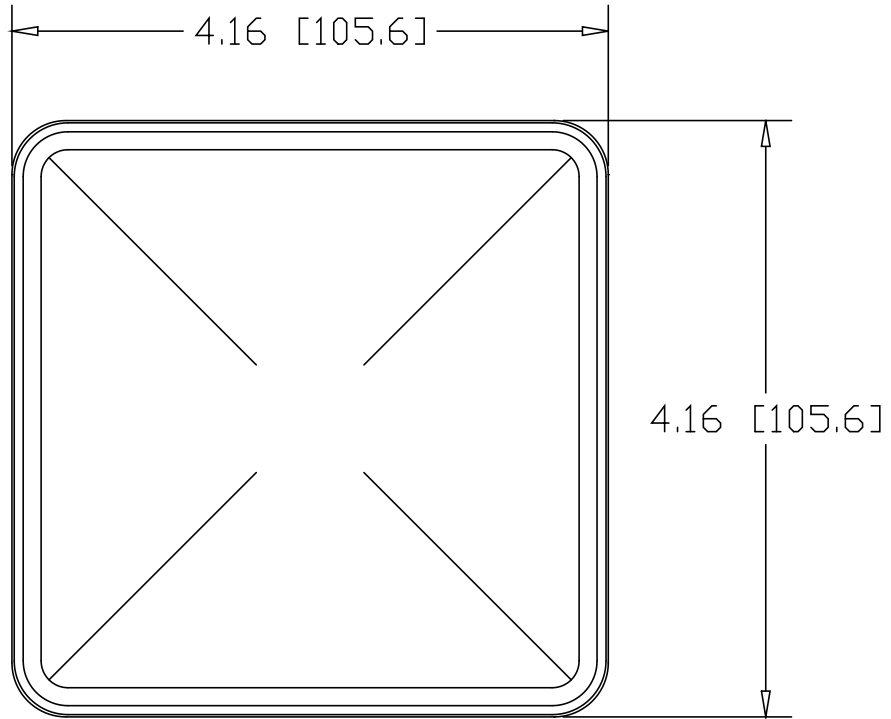

INCHES [MILLIMETERS]

ALTERNATE MATERIAL	PART NUMBER
.050 (3003) ALUMINUM ASTM B209	5121
18 GA. (304) STAINLESS STEEL ASTM A240	5123

PART NAME		4" NEWEL POST CAP					
MATERIAL		18 GA. STEEL ASTM A-366					
DATE	10/26/93	 <b>THE WAGNER COMPANIES</b> R & B WAGNER, INC. AND J. G. BRAUN CO.					
DRAWN BY	RJF						
FINISH	MILL						
SIZE	A	WEIGHT	.44 lbs	PART NUMBER	5120	REV	A