

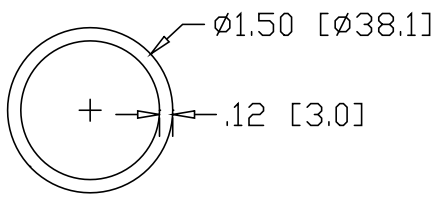

REV
SH
6958
DWG NO

REVISIONS			
REV	DESCRIPTION	DATE	APPROVED

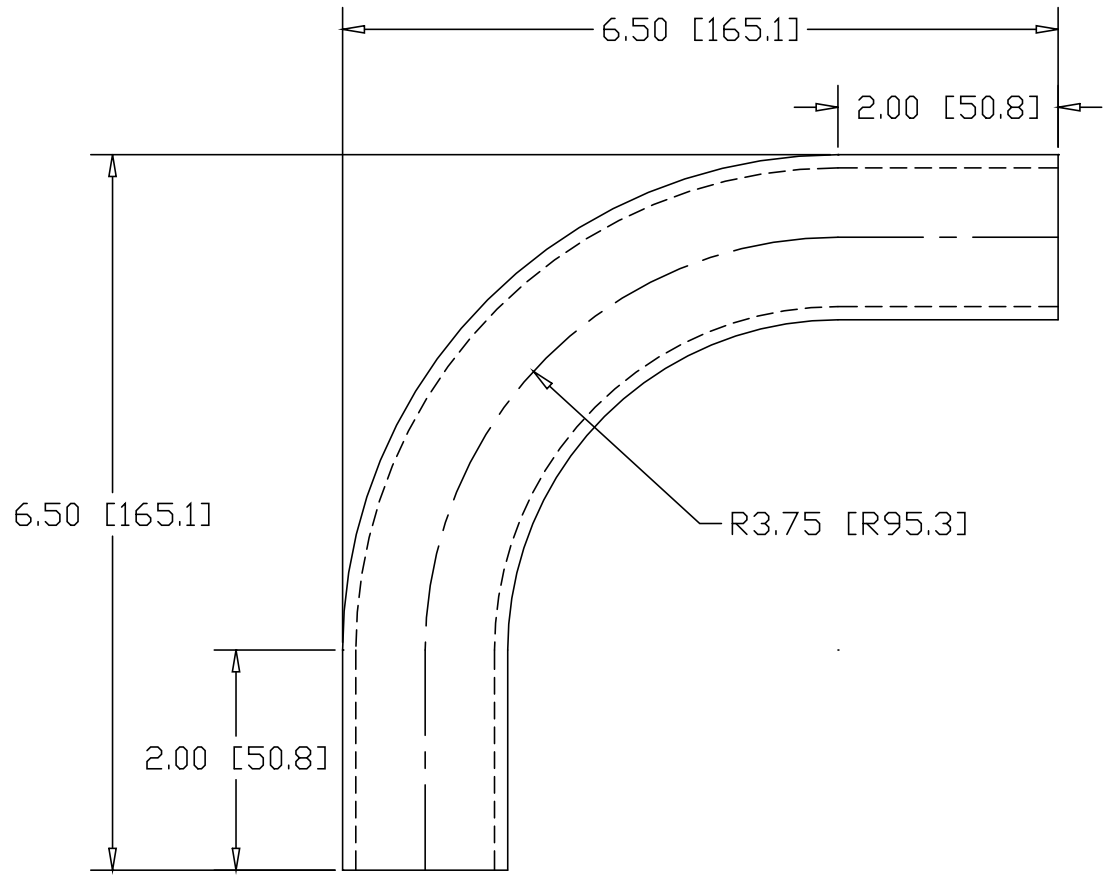

INCHES [MILLIMETERS]

ALTERNATE MATERIAL	PART NUMBER
1.50" O.D. X .125W (6061-T1) ALUMINUM TUBE	6969
1.50" O.D. X .120W (304) STAINLESS STEEL TUBE	6977

PART NAME 1.50" O.D. TUBE 90° ELL X 3.75" CLR W/(2) 2" TANGENTS			
MATERIAL 1.50" O.D. X .120W STEEL TUBE			
DATE 9/22/00		R & B WAGNER, INC.	
DRAWN BY RJF			
FINISH MILL		SIZE A	WEIGHT 1.46 LBS
			REV