

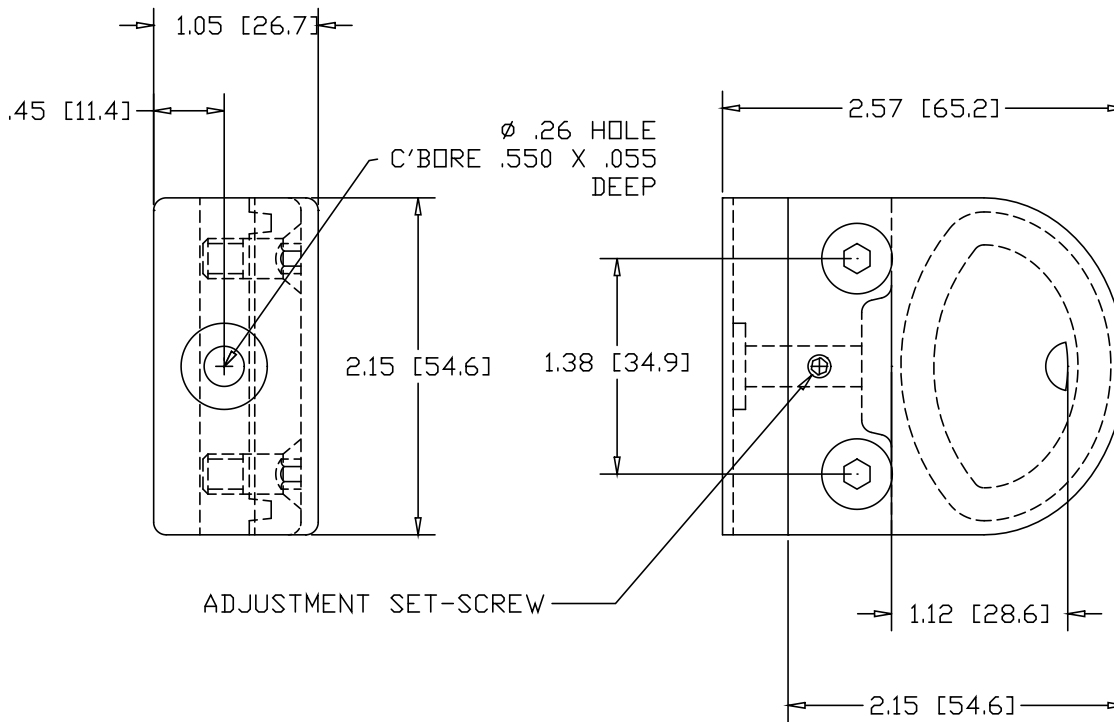

REV
SH
152816-2
DWG NO

REVISIONS			
REV	DESCRIPTION	DATE	APPROVED

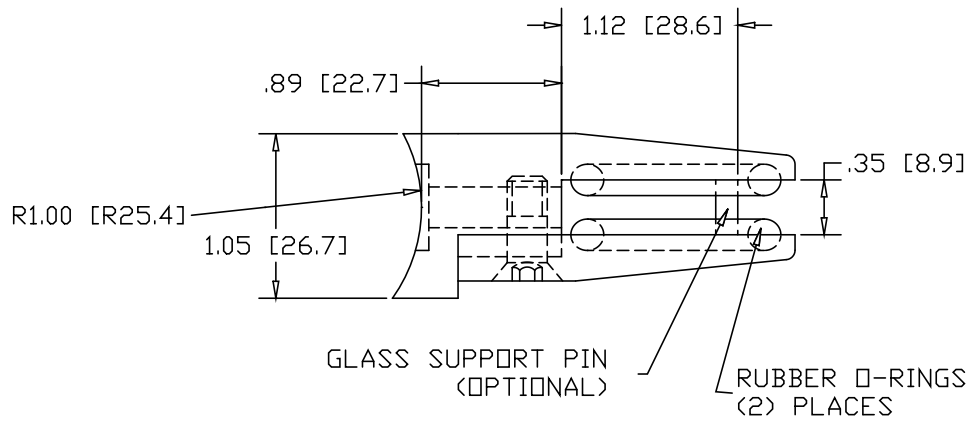

INCHES [MILLIMETERS]

PART NAME GLASSGRIP ROUND MOUNTING FOR .25" - .38" GLASS			
MATERIAL TYPE 304 STAINLESS STEEL			
DATE	4/29/05	 THE WAGNER COMPANIES R & B WAGNER, INC. AND J. G. BRAUN CO.	REV
DRAWN BY	DGP		
FINISH	SATIN		
SIZE	A	WEIGHT	.76 LBS
PART NUMBER		152816-2	