

REV A
SH
DWG NO 5733B

REVISIONS			
REV	DESCRIPTION	DATE	APPROVED
A	CHANGED 5761B TO SCH 10, WAS SCH 40	08/26/14	RJF

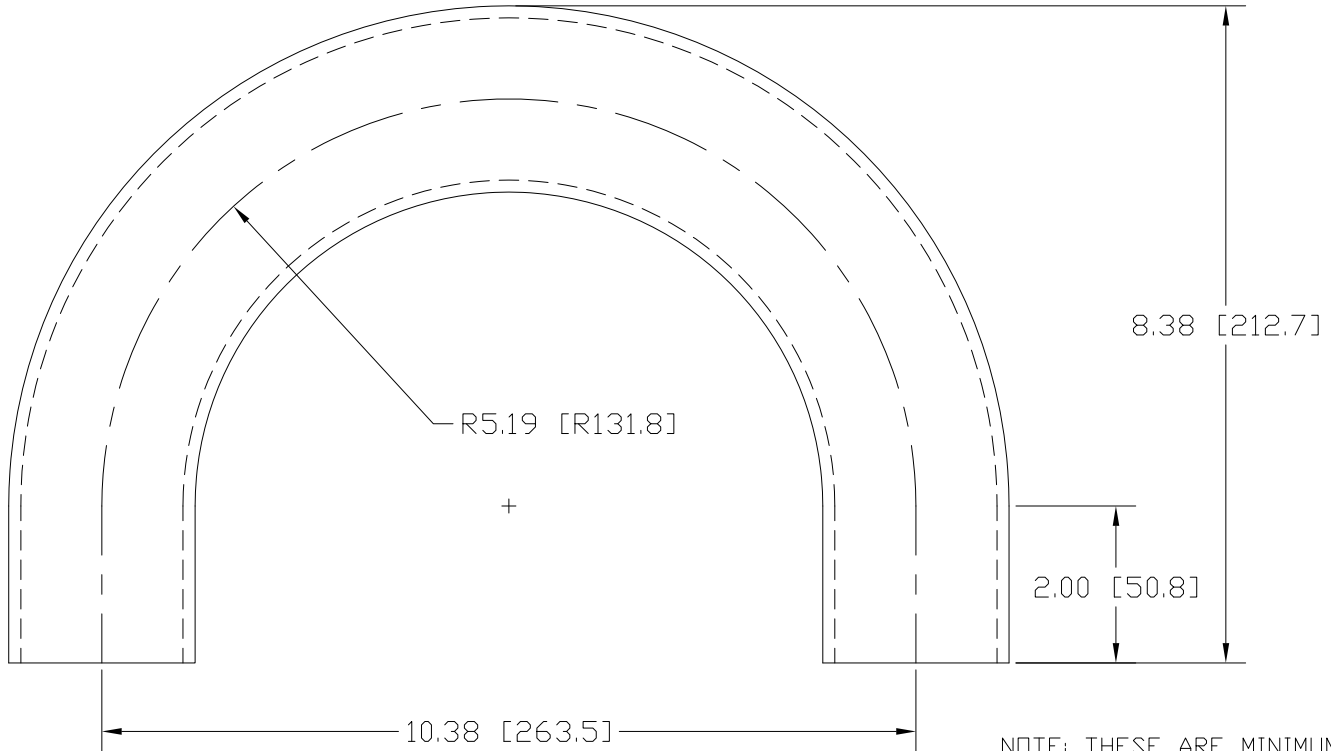

NOTE: THESE ARE MINIMUM DIMENSIONS, ENDS ARE LEFT UNTRIMMED

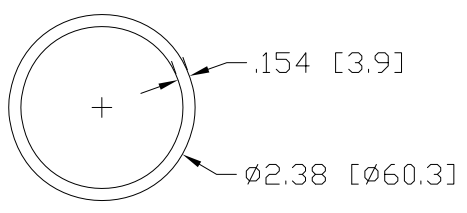

INCHES [MILLIMETERS]

ALTERNATE MATERIAL	PART NUMBER
2" SCH 40 (6063) ALUMINUM PIPE	5747B
2" SCH 10 (304) STAINLESS STEEL PIPE	5761B

PART NAME 2" PIPE SIZE 180° X 4" I.R. ELL W/(2) 2" TANGENTS			
MATERIAL 2" SCH 40 STEEL PIPE			
DATE 4/9/96		R & B WAGNER, INC.	
DRAWN BY RJF		SIZE A	WEIGHT 6.76 LBS
FINISH MILL			REV A