

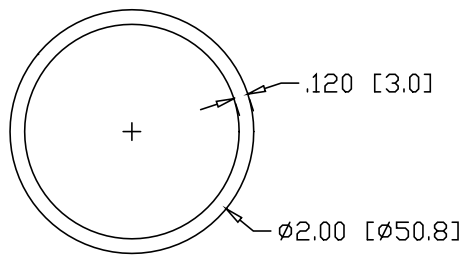

REV  
SH  
7962  
DWG NO

REVISIONS			
REV	DESCRIPTION	DATE	APPROVED

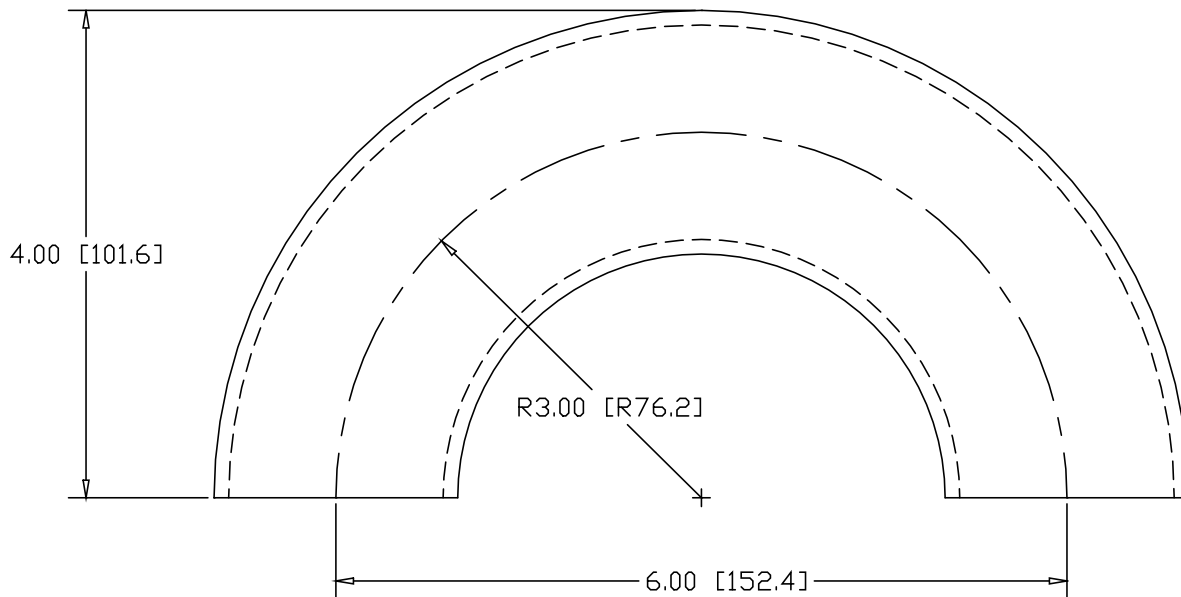

INCHES [MILLIMETERS]

ALTERNATE MATERIAL	PART NUMBER
2" Ø.D. X .125W (6061) ALUMINUM TUBE	7978
2" Ø.D. X .120W (304) STAINLESS STEEL TUBE	7994

PART NAME		2" Ø.D. TUBE 180° ELL X 3"CLR					
MATERIAL		2" Ø.D. X .120W STEEL TUBE					
DATE	8/24/00	 <b>R &amp; B WAGNER, INC.</b>					
DRAWN BY	RJF						
FINISH	MILL						
SIZE	A	WEIGHT	1.90 LBS	PART NUMBER	7962	REV	