

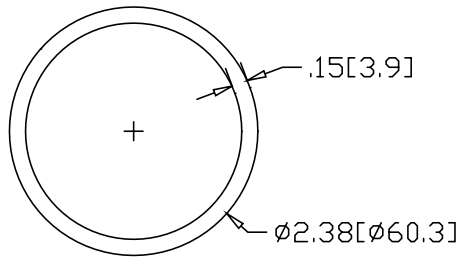

REV
SH
423
DWG NO

REVISIONS			
REV	DESCRIPTION	DATE	APPROVED

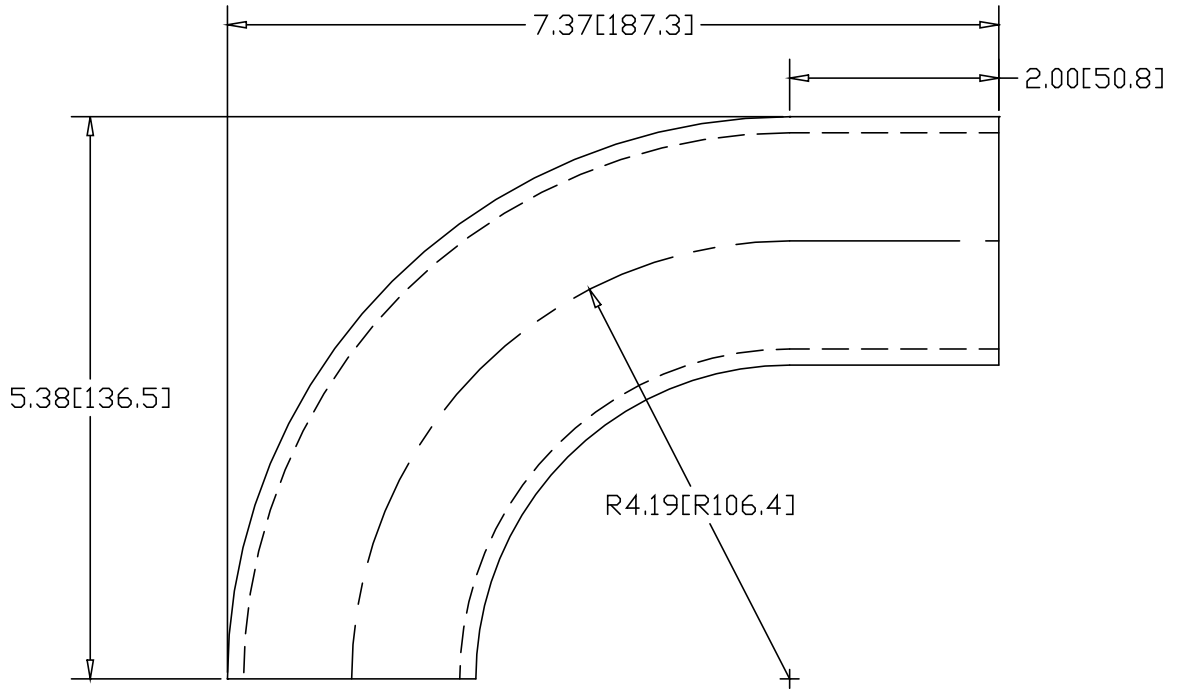

INCHES [MILLIMETERS]

ALTERNATE MATERIAL	PART NUMBER
2" SCH 40 (6063) ALUMINUM PIPE	445
2" SCH 40 (304) STAINLESS STEEL PIPE	460

PART NAME 2" PIPE SIZE 90° X 3" I.R. ELL W/(1) 2" TANGENT				
MATERIAL 2" SCH 40 STEEL PIPE				
DATE 9/14/95	 R & B WAGNER, INC.			
DRAWN BY RJF				
FINISH MILL	SIZE A	WEIGHT 2.61 LBS	PART NUMBER 423	REV