

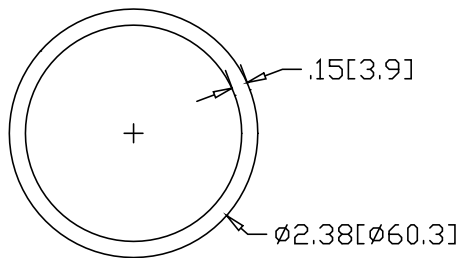

REV
SH
423
DWG NO

| REVISIONS | | | |
|-----------|-------------|------|----------|
| REV | DESCRIPTION | DATE | APPROVED |

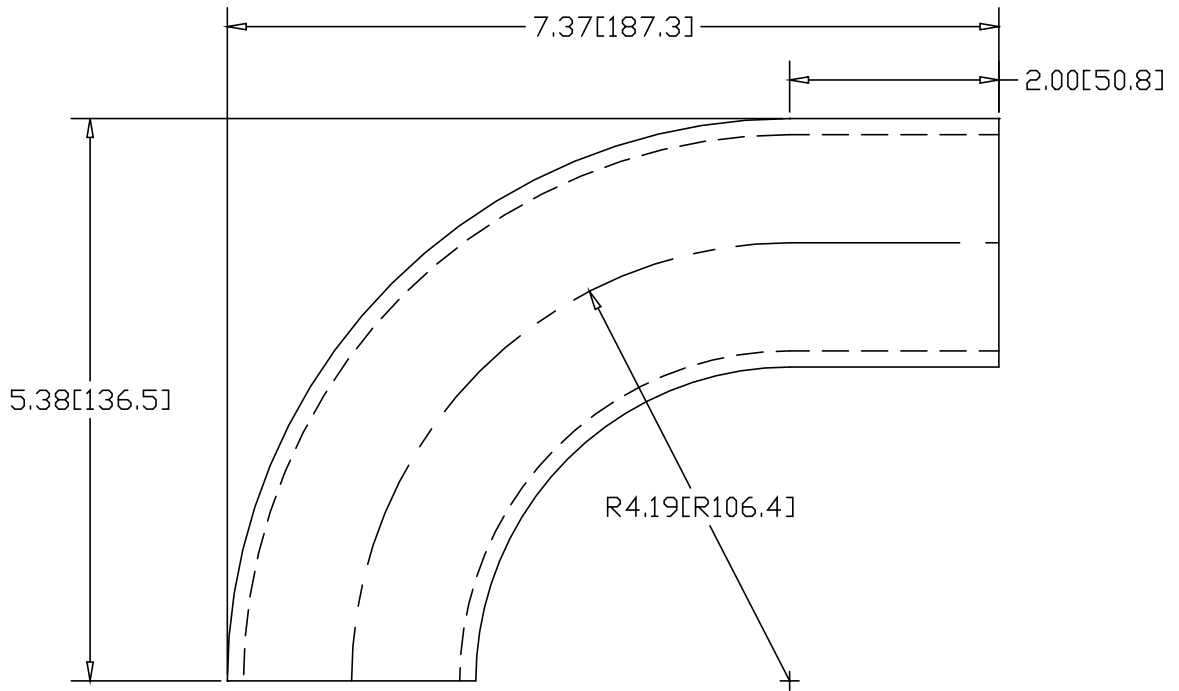

INCHES [MILLIMETERS]

| ALTERNATE MATERIAL | PART NUMBER |
|--------------------------------------|-------------|
| 2" SCH 40 (6063) ALUMINUM PIPE | 445 |
| 2" SCH 40 (304) STAINLESS STEEL PIPE | 460 |

| | | | | |
|-----------------------------------------------------------|-------------------------------------------------------------------------------------------------------------------|-----------------|-----------------|-----|
| PART NAME 2" PIPE SIZE 90° X 3" I.R. ELL W/(1) 2" TANGENT | | | | |
| MATERIAL 2" SCH 40 STEEL PIPE | | | | |
| DATE 9/14/95 |  R & B WAGNER, INC. | | | |
| DRAWN BY RJF | | | | |
| FINISH MILL | SIZE A | WEIGHT 2.61 LBS | PART NUMBER 423 | REV |