

REV
SH
1611
DWG NO

REVISIONS			
REV	DESCRIPTION	DATE	APPROVED

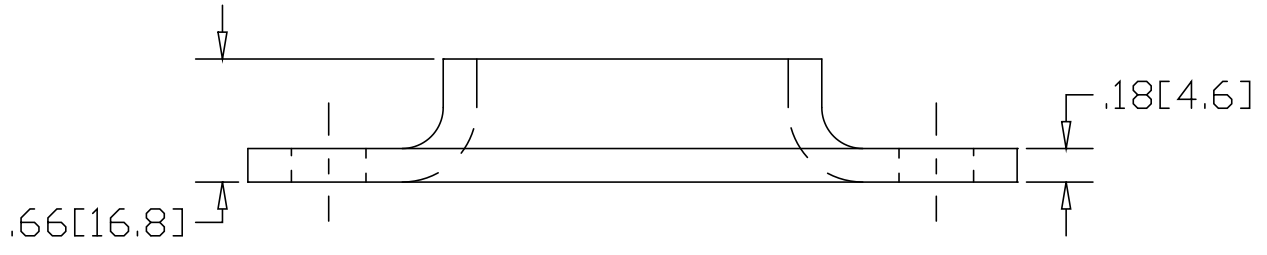
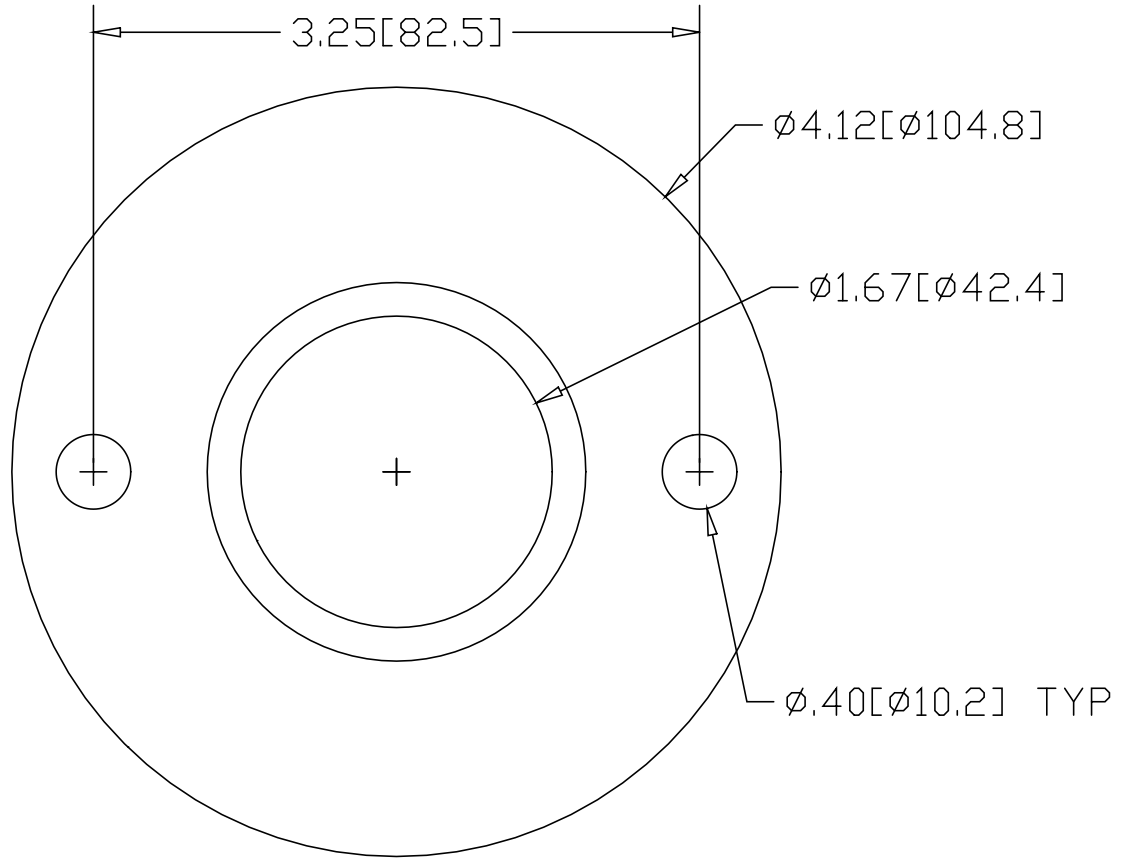

INCHES [MILLIMETERS]

*USE WITH ANCHOR PLATE
#B1608 IN STEEL
#B1658 IN ALUMINUM

ALTERNATE MATERIAL	PART NUMBER
3/16" (3003) ALUMINUM ASTM B-209	1631

PART NAME		1-1/4" PIPE SIZE EXTRA HEAVY FLANGE W/(2) HOLES			
MATERIAL		3/16" HRP&O STEEL ASTM A-569			
DATE	1/15/95	 R & B WAGNER, INC.			
DRAWN BY	RJF				
FINISH	MILL	SIZE	WEIGHT	PART NUMBER	REV
		A	.6 LBS	1611	