

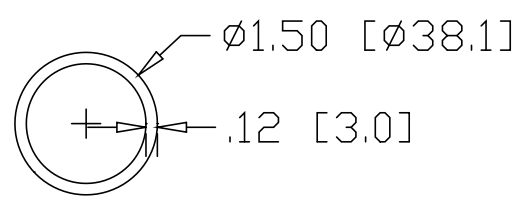

REV  
SH  
6958-6  
DWG NO

REVISIONS			
REV	DESCRIPTION	DATE	APPROVED

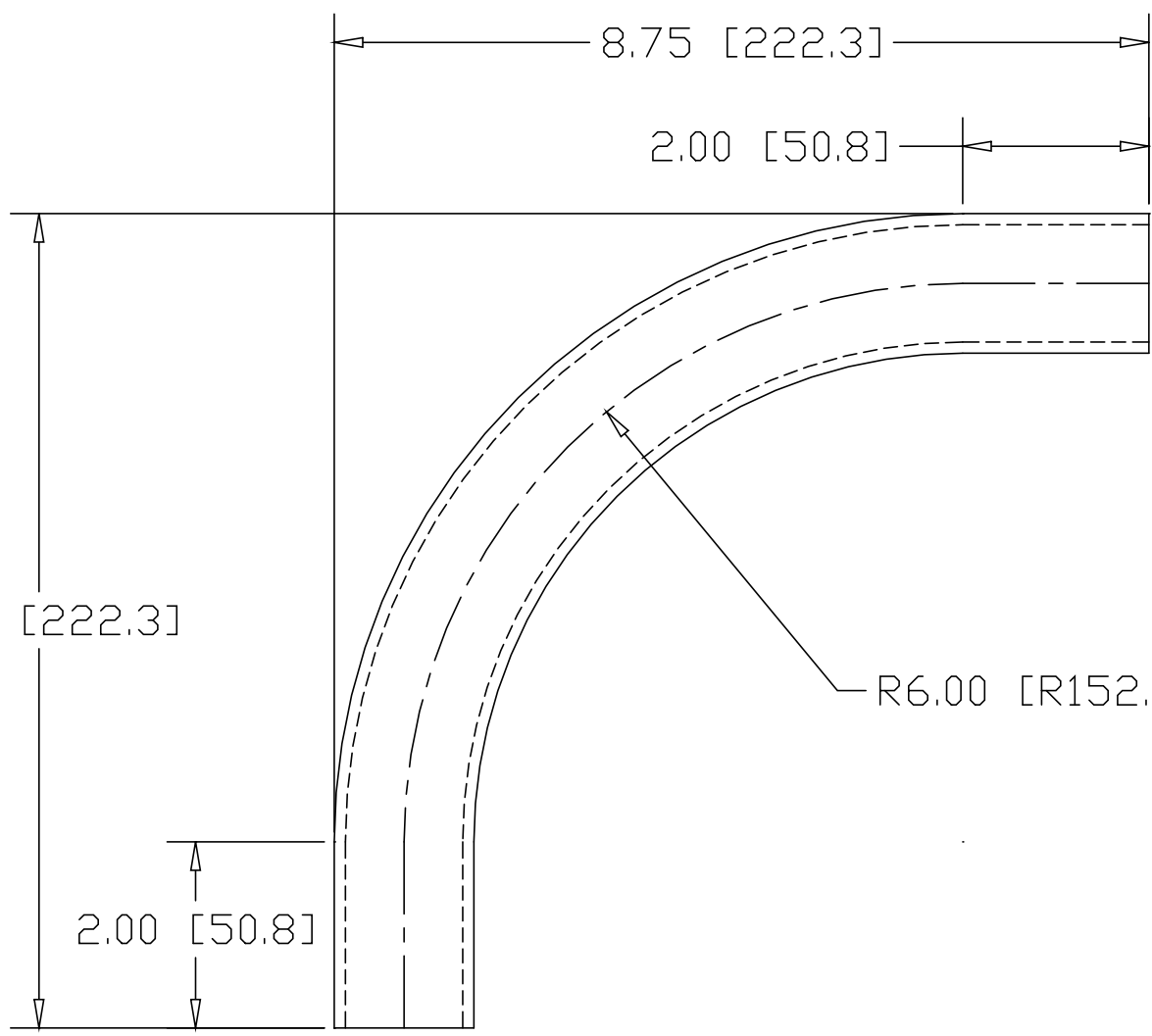

INCHES [MILLIMETERS]

ALTERNATE MATERIAL	PART NUMBER
1.50" O.D. X .125W (6061-T1) ALUMINUM TUBE	6969-6
1.50" O.D. X .120W (304) STAINLESS STEEL TUBE	6977-6

PART NAME 1.50" O.D. TUBE 90° ELL X 6.00" CLR W/(2) 2" TANGENTS			
MATERIAL 1.50" O.D. X .120W STEEL TUBE			
DATE 9/22/00		R & B WAGNER, INC.	
DRAWN BY RJF		SIZE A	WEIGHT 1.98 LBS
FINISH MILL		PART NUMBER 6958-6	REV