

REVISIONS			
REV	DESCRIPTION	DATE	APPROVED

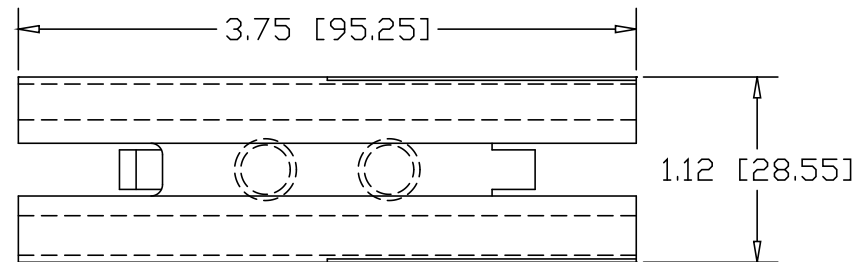

1.50" SQ. .188W TUBE

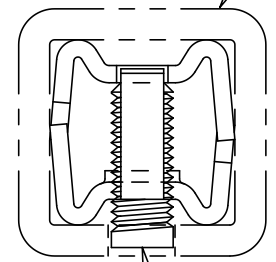

3/8-16 SOCKET HEAD SET-SCREW (2) PLACES

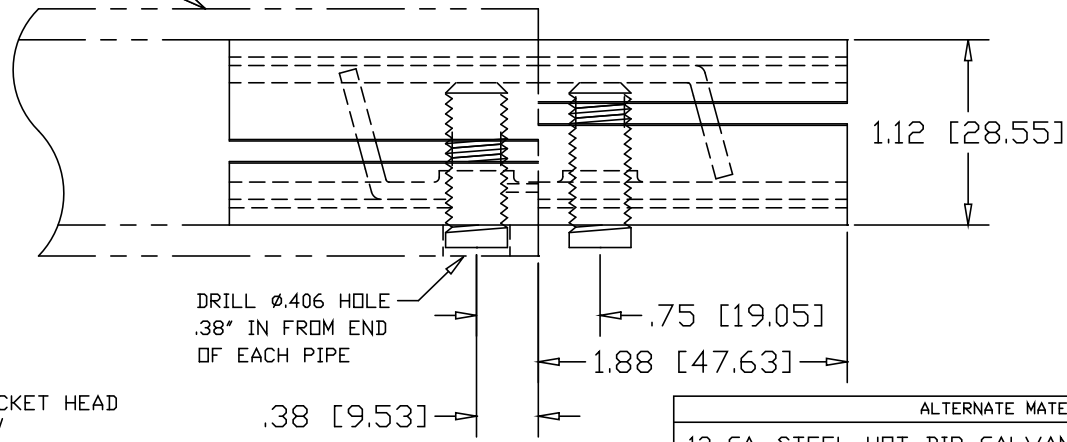

DRILL ϕ .406 HOLE .38" IN FROM END OF EACH PIPE

ALTERNATE MATERIAL	PART NO.
12 GA. STEEL HOT DIP GALVANIZED	G3385-2
12 GA. STEEL ZINC PLATED	PL3385-2
.090 (3003) ALUMINUM ASTM B209	3386-2
.090 (304) STAINLESS STEEL ASTM A240	3387-2

PART NAME		1.50" SQ. .188W TUBE DOUBLE-LOCK SPLICE-LOCK					
MATERIAL		12 GA. HRP&D STEEL ASTM A569					
DATE	9/26/01	 R & B WAGNER, INC.					
DRAWN BY	JAH						
FINISH	MILL						
SIZE	A	WEIGHT	.44 LBS	PART NUMBER	3385-2	REV	