

REV
SH
8113B
DWG NO

REVISIONS			
REV	DESCRIPTION	DATE	APPROVED

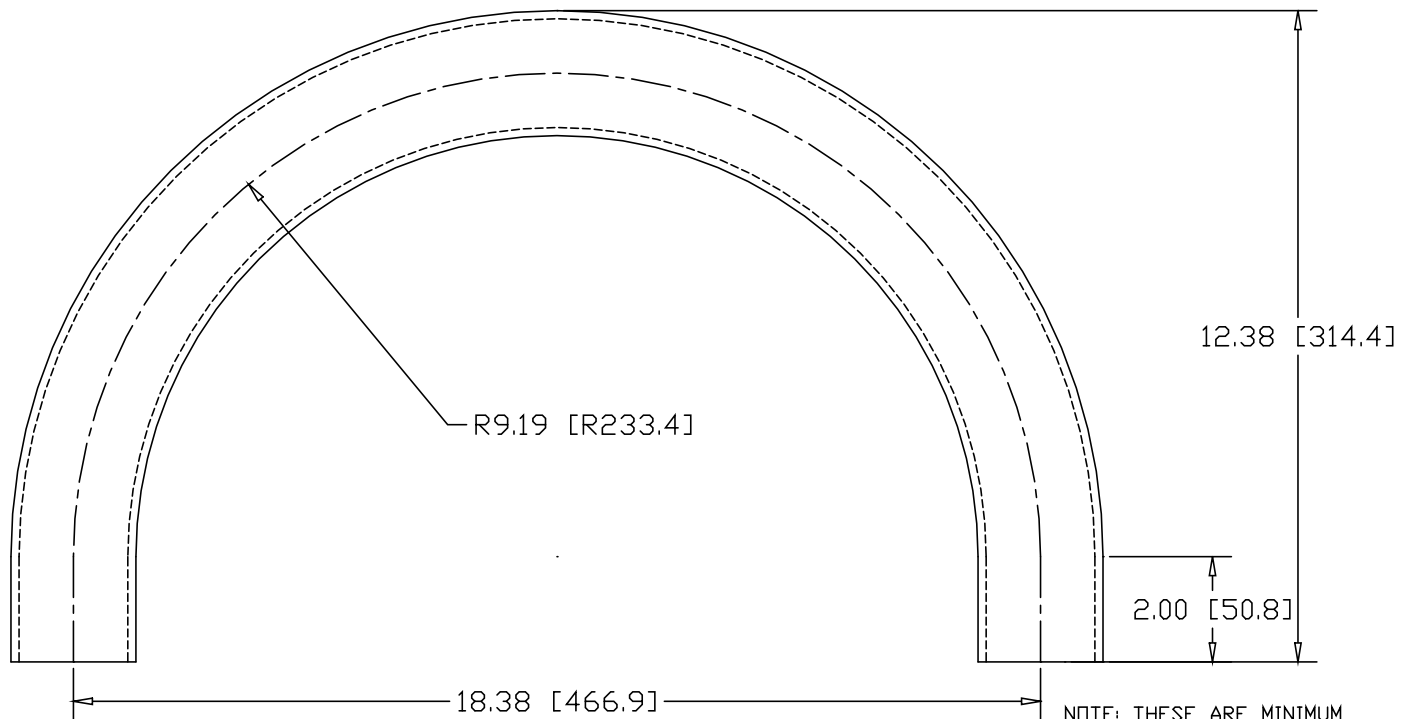

NOTE: THESE ARE MINIMUM DIMENSIONS, ENDS ARE LEFT UNTRIMMED.

INCHES [MILLIMETERS]

ALTERNATE MATERIAL	PART NUMBER
2" SCH 40 (6063) ALUMINUM PIPE	8127B
2" SCH 40 (304) STAINLESS STEEL PIPE	8141B

PART NAME 2" PIPE SIZE 180° ELL X 8" I.R. W/ (2) 2" TANGENTS				
MATERIAL 2" SCH 40 A53 STEEL PIPE				
DATE 7/31/01	 R & B WAGNER, INC.			
DRAWN BY JAH				
FINISH MILL	SIZE A	WEIGHT 10.03 LBS	PART NUMBER 8113B	REV