

REV
SH
7914
DWG NO

REVISIONS			
REV	DESCRIPTION	DATE	APPROVED

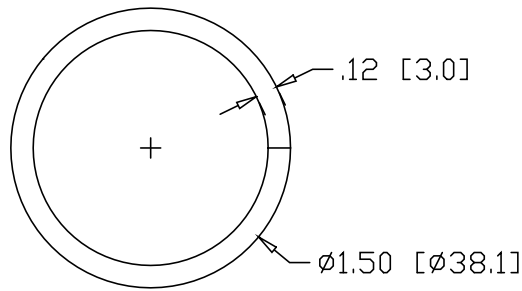
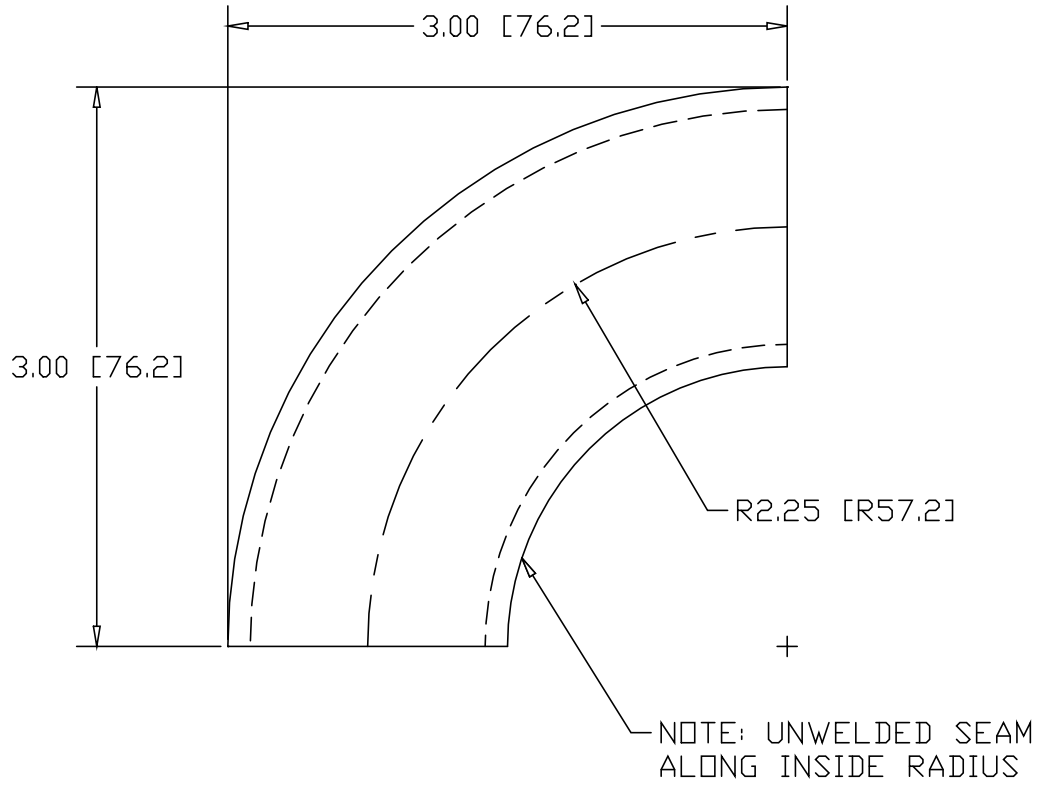

INCHES [MILLIMETERS]

ALTERNATE MATERIAL	PART NUMBER
.125 (3003) ALUMINUM ASTM B209	7930
11 GA. (304) STAINLESS STEEL ASTM A240	7946

PART NAME		1.50" OD TUBE 2.25" CLR 90° ELL		
MATERIAL		11 GA. HRP&D STEEL ASTM A569		
DATE	8/25/03			
DRAWN BY	RJF			
FINISH	MILL			
SIZE	WEIGHT	PART NUMBER	REV	
A	.45 LBS	7914		