

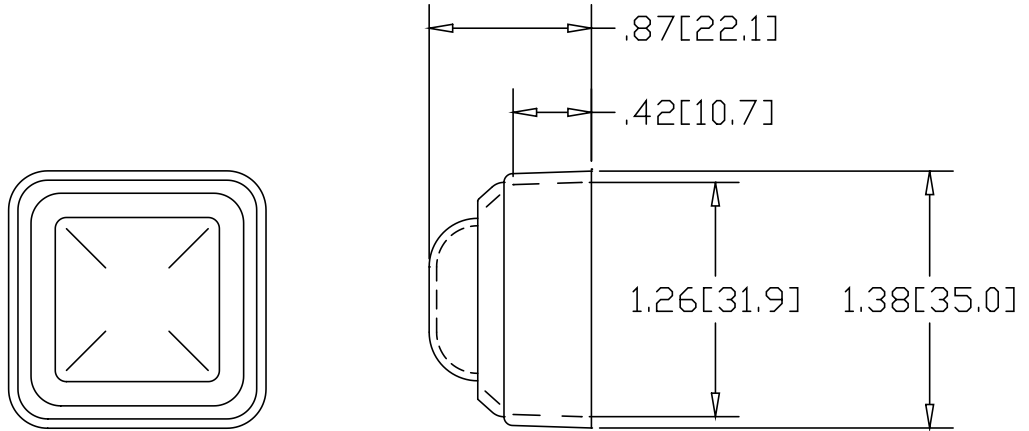

REV
SH
DWG NO 5162

REVISIONS			
REV	DESCRIPTION	DATE	APPROVED



INCHES [MILLIMETERS]

ALTERNATE MATERIAL	PART NUMBER
.050 (3003) ALUMINUM ASTM B209	5163
18 GA. 304 STAINLESS STEEL	5164

PART NAME		1.25" SQUARE NEWEL POST CAP		
MATERIAL		18 GA. CR STEEL ASTM A366		
DATE	11/19/97	 THE WAGNER COMPANIES R & B WAGNER, INC. AND J. G. BRAUN CO.		
DRAWN BY	RJF			
FINISH	MILL			
SIZE	WEIGHT	PART NUMBER	REV	
A	.05 lbs	5162		