

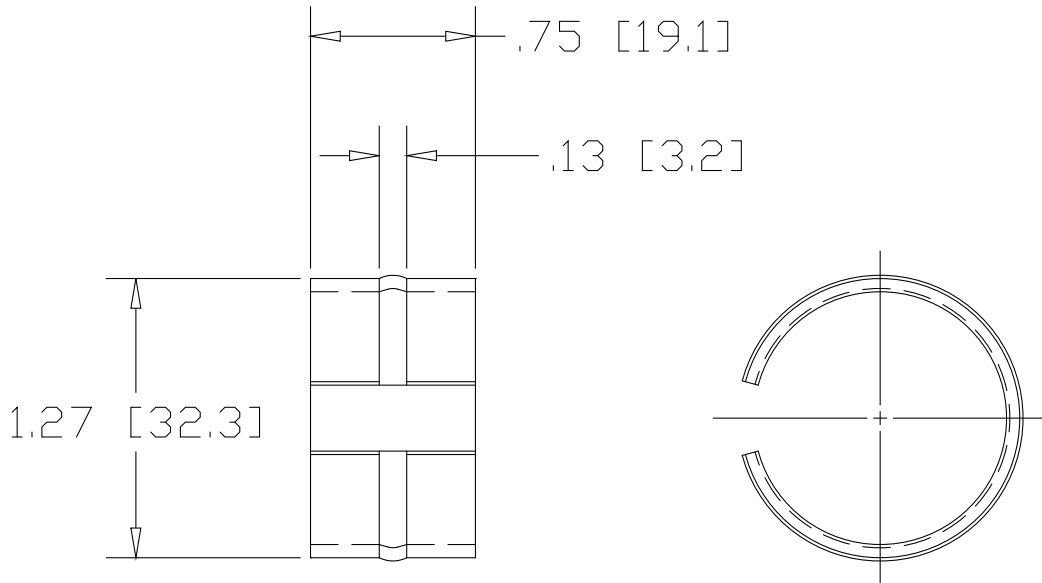

DWG NO 1023T.11
SH
REV

REVISIONS			
REV	DESCRIPTION	DATE	APPROVED

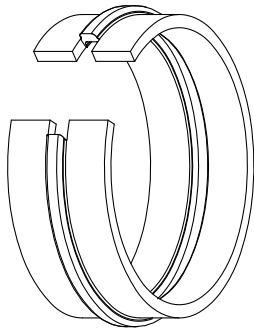

INCHES [MILLIMETERS]

ALTERNATE MATERIAL	PART NUMBER
.063 (3003) ALUMINUM ASTM B209	1024T.11
.0595 (304) STAINLESS STEEL ASTM A240	1025T.11

PART NAME 1.50" OD .125W TUBE WEDGE-LOCK WELDING CONNECTOR				
MATERIAL 16 GA. (.063) HRP&O STEEL ASTM A569				
DATE 10/10/01	 THE WAGNER COMPANIES R & B WAGNER, INC. AND J. G. BRAUN CO.			
DRAWN BY JAH				
FINISH MILL	SIZE A	WEIGHT .04 LBS	PART NUMBER 1023T.11	REV