

Ø.275 (2) PLACES

REVISION HISTORY			
REV	DESCRIPTION	DATE	APPROVED
1	REDRAWN	12/29/09	RK
2	REDRAWN TO CURRENT FORM TOOL	08/14/17	RJF

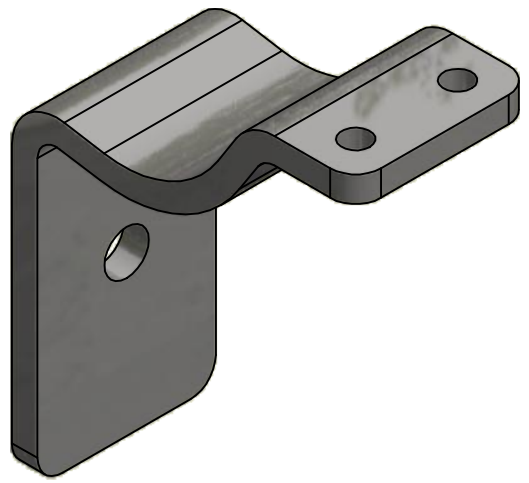
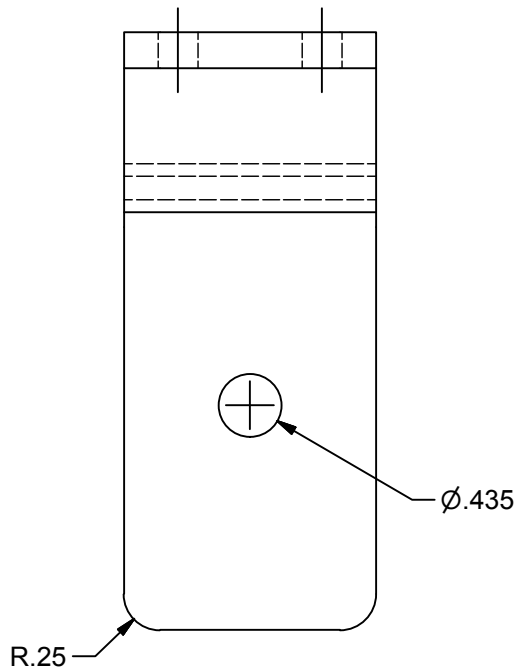
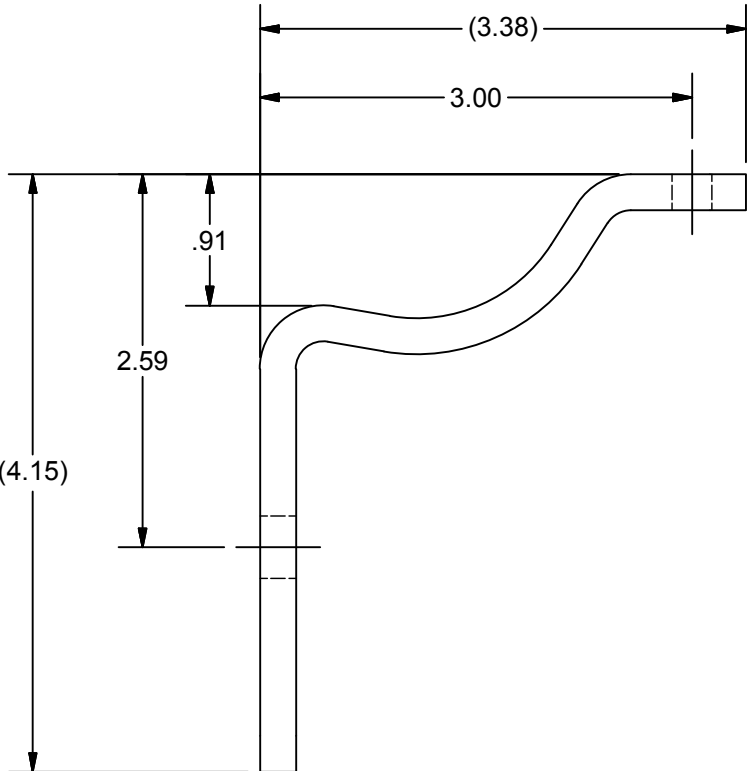

NAME					BRACKET, EXTRUDED STYLE STAMPED, FLAT SADDLE				
MATERIAL					.250 STEEL ASTM A1018				
DATE		3/25/1993			COLLABORATIVE METAL WORKS				
DRAWN		RJF							
FINISH		MILL							
SIZE	WEIGHT	PART NUMBER			REV				
A	.801 LBS	1978F			2				