

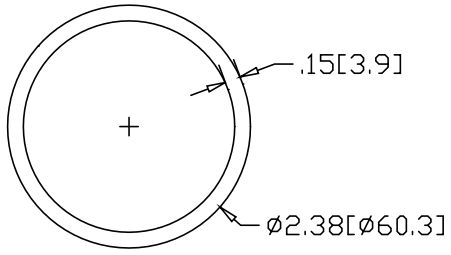

REV
SH
436
DWG NO

REVISIONS			
REV	DESCRIPTION	DATE	APPROVED

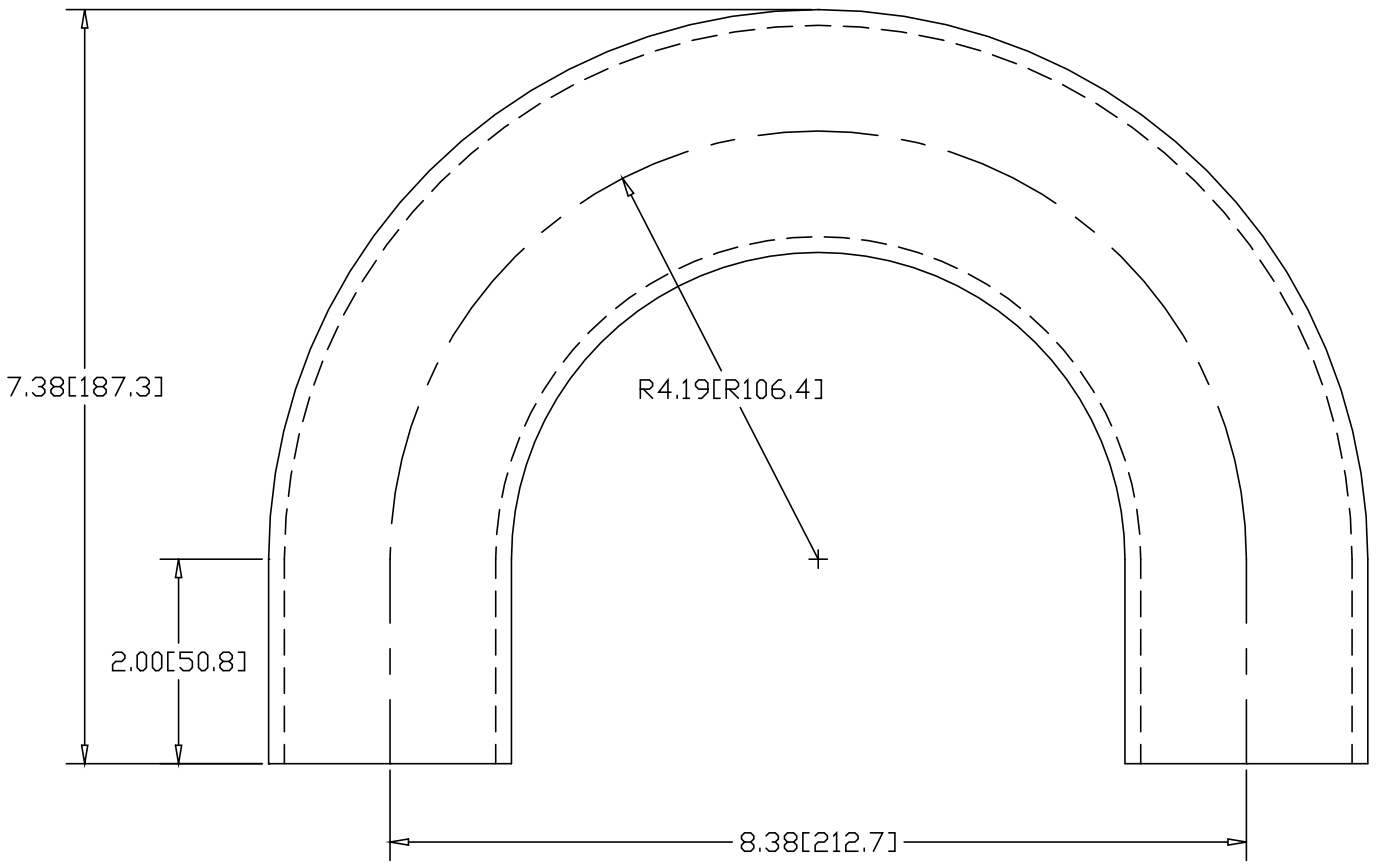

INCHES [MILLIMETERS]

ALTERNATE MATERIAL	PART NUMBER
2" SCH 40 (6063) ALUMINUM PIPE	452
2" SCH 40 (304) STAINLESS STEEL PIPE	470

PART NAME		2" PIPE SIZE 180° X 3" I.R. ELL W/(2) 2" TANGENTS					
MATERIAL		2" SCH 40 STEEL PIPE					
DATE	9/14/95	 R & B WAGNER, INC.					
DRAWN BY	RJF						
FINISH	MILL						
SIZE	A	WEIGHT	5.22 LBS	PART NUMBER	436	REV	