

REVISION HISTORY

REV	DESCRIPTION	DATE	APPROVED
A	REDRAWN	2/3/2016	RJF

- A - \square 0.030

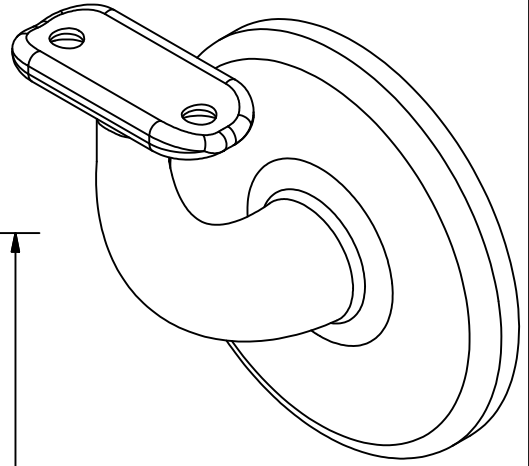
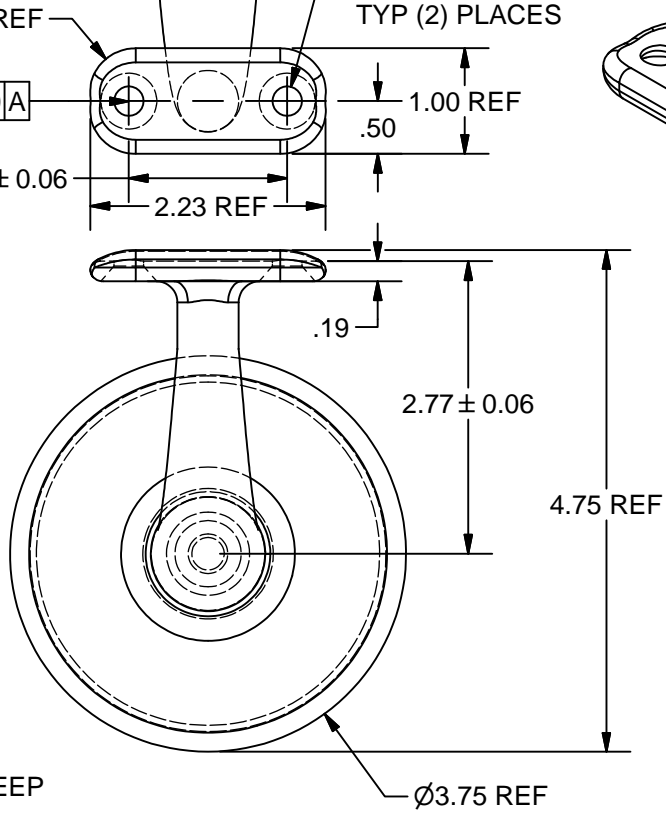
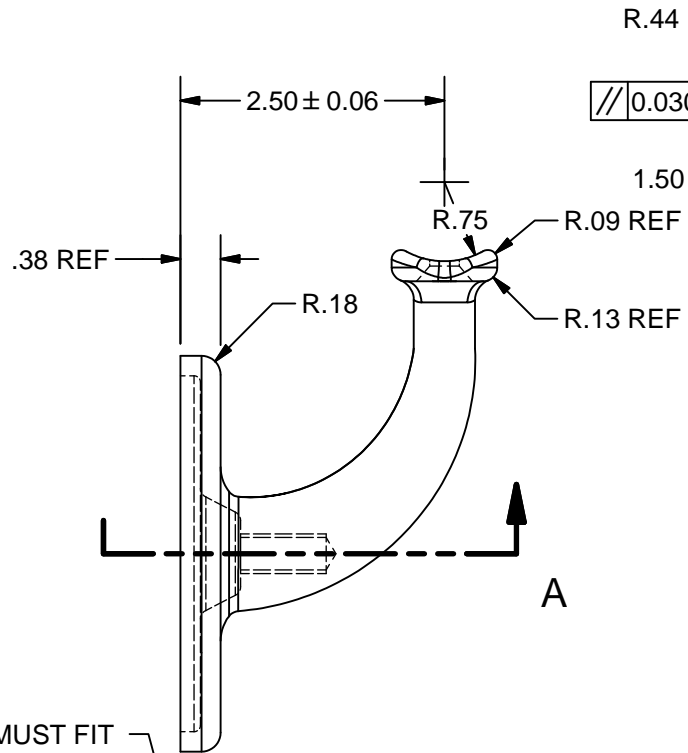
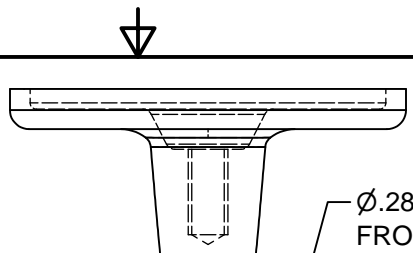

CAVITY MUST FIT
Ø3.19 X .188 GAGE

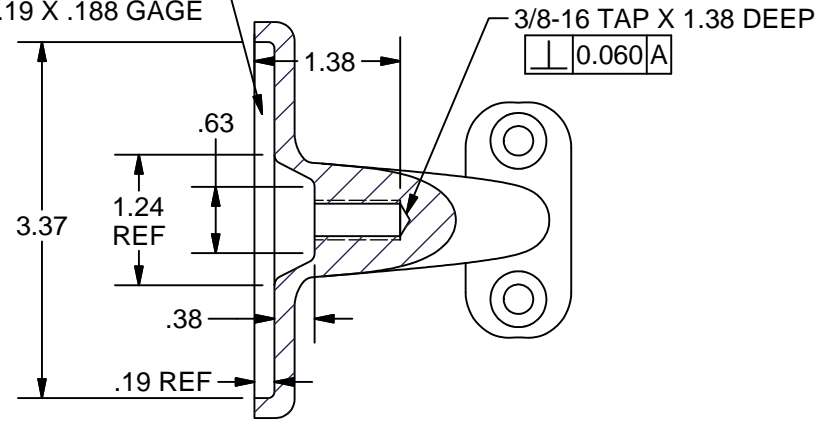

SECTION A-A

NAME 2-1/2" CAST HANDRAIL BRACKET WITH UNIVERSAL SADDLE				
MATERIAL (304) STAINLESS STEEL ASTM A743				
DATE 7/27/2006		COLLABORATIVE METAL WORKS		
DRAWN RJF				
FINISH #4 SATIN				
SIZE A	WEIGHT 1.540 lbs	PART NUMBER 1729-2	REV A	