

REV
SH
2535A
DWG NO

REVISIONS			
REV	DESCRIPTION	DATE	APPROVED

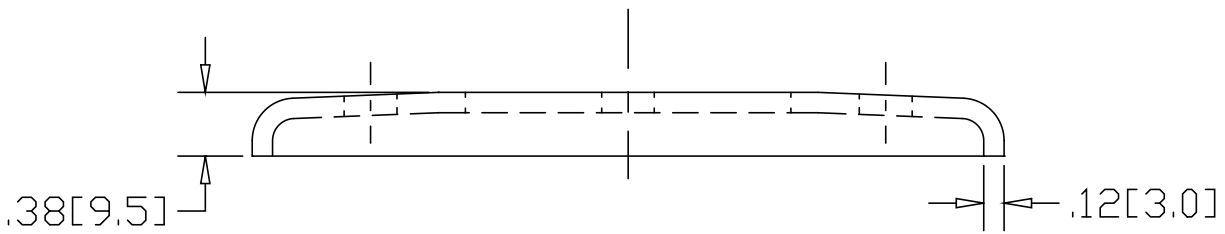
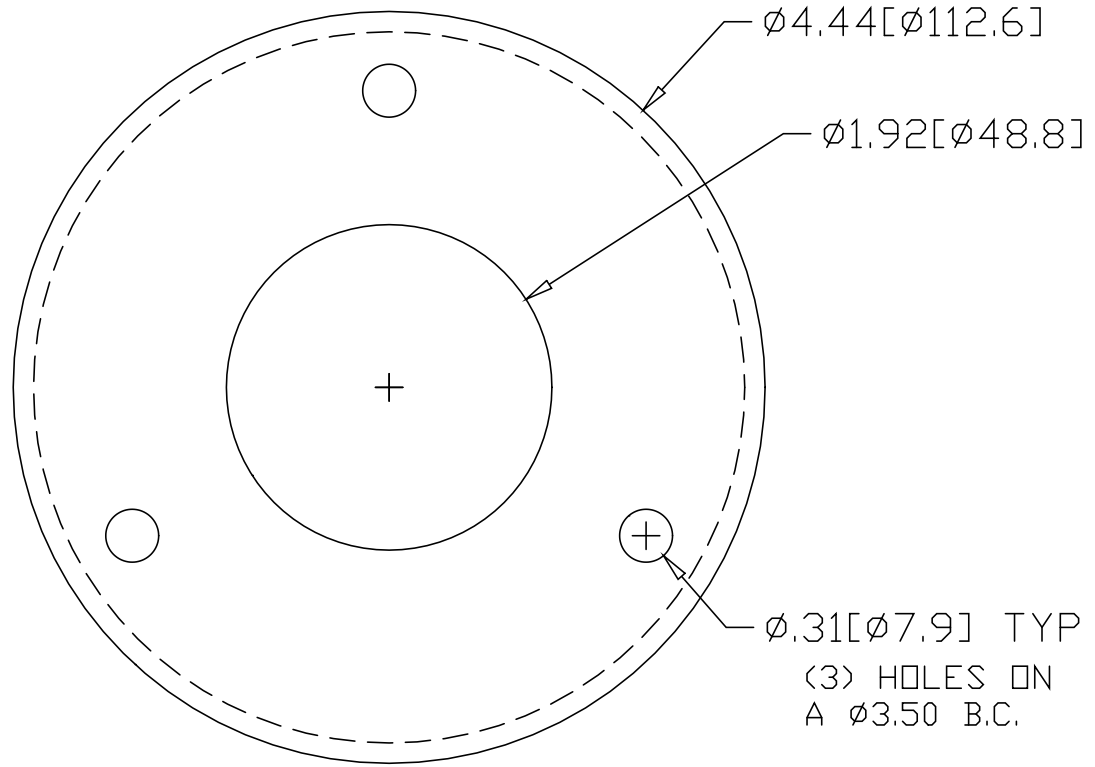

INCHES [MILLIMETERS]

*USE WITH ANCHOR PLATE
 #B1440 IN STEEL
 #PLB1440 ZINC PLATED STEEL
 #B1540 IN STAINLESS

ALTERNATE MATERIAL	PART NUMBER
.125 (3003) ALUMINUM ASTM B209	2575A
10 GA. (304) STAINLESS STEEL ASTM A240	2615A

PART NAME 1-1/2" PIPE HEAVY FLUSH BASE FLANGE W/(3) HOLES			
MATERIAL 10 GA. HRP&D STEEL ASTM A569			
DATE 9/6/94	 R & B WAGNER, INC.		
DRAWN BY RJF			
FINISH MILL	SIZE A	WEIGHT .52 LBS	PART NUMBER 2535A
			REV