

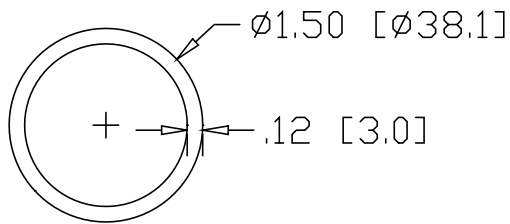

REV  
SH  
DWG NO 6953

REVISIONS			
REV	DESCRIPTION	DATE	APPROVED

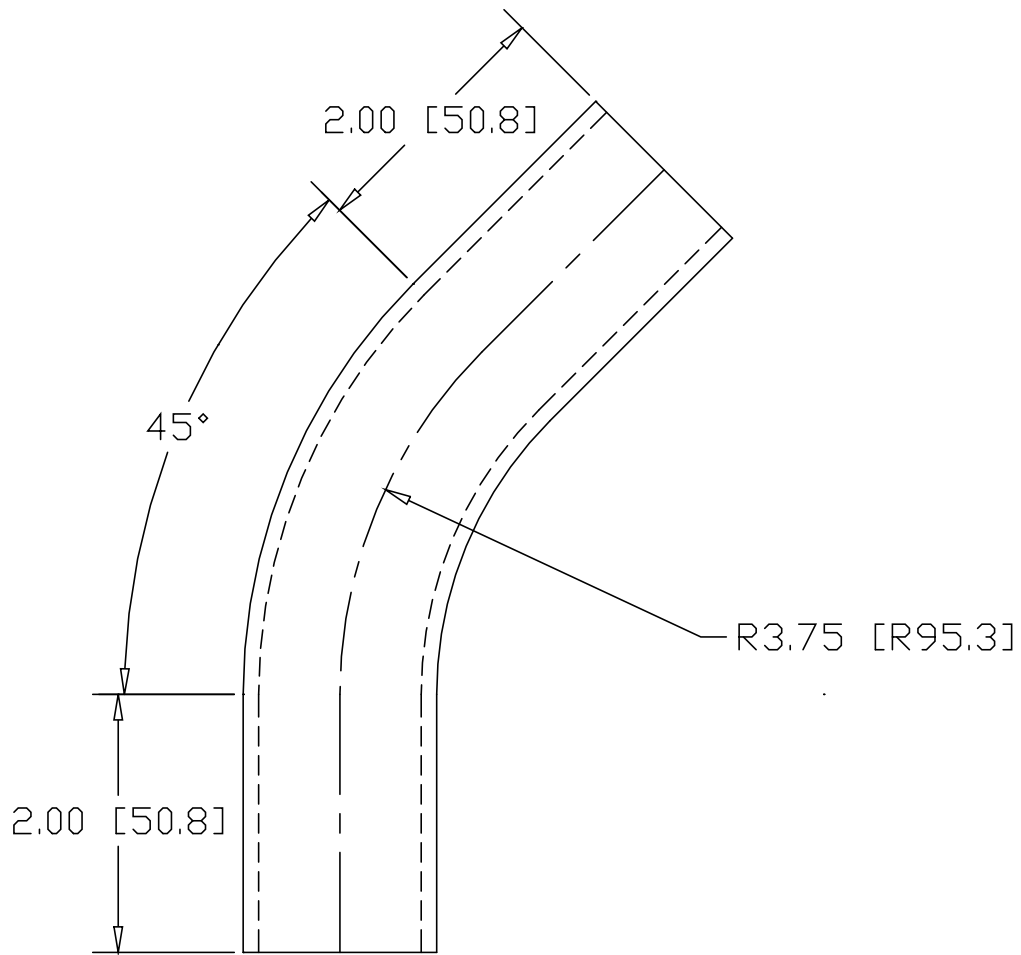

INCHES [MILLIMETERS]

ALTERNATE MATERIAL	PART NUMBER
1.50" O.D. X .125W (6061-T1) ALUMINUM TUBE	6965
1.50" O.D. X .120W (304) STAINLESS STEEL TUBE	6973

PART NAME 1.50" O.D. TUBE 45° ELL X 3.75" CLR W/(2) 2" TANGENTS			
MATERIAL 1.50" O.D. X .120W STEEL TUBE			
DATE 9/22/00	 <b>R &amp; B WAGNER, INC.</b>		
DRAWN BY RJF			
FINISH MILL	SIZE A	WEIGHT 1.03 LBS	PART NUMBER 6953
			REV