

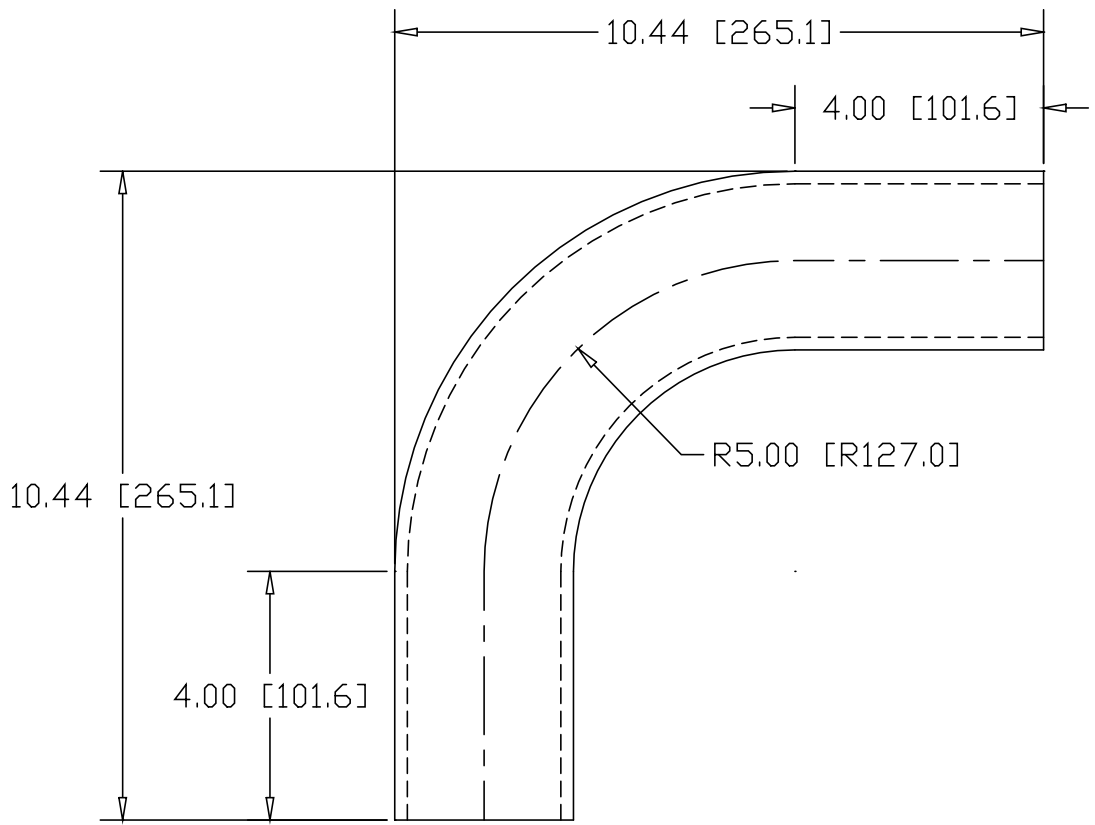

REV  
SH  
9601  
DWG NO

REVISIONS			
REV	DESCRIPTION	DATE	APPROVED



INCHES [MILLIMETERS]

ALTERNATE MATERIAL	PART NUMBER
2-1/2" SCH 40 6063 ALUMINUM PIPE	9604
2-1/2" SCH 40 304 STAINLESS STEEL PIPE	9606
2-1/2" SCH 40 230 RED BRASS PIPE	9608

PART NAME 2-1/2" PIPE SIZE 90° ELL X 5" CLR W/(2) 4" TANGENTS			
MATERIAL 2-1/2" SCH 40 STEEL PIPE			
DATE 9/2/03		<b>THE WAGNER COMPANIES</b> R & B WAGNER, INC. AND J. G. BRAUN CO.	
DRAWN BY RJF			
FINISH MILL			
SIZE A	WEIGHT 7.65 LBS	PART NUMBER 9601	REV