

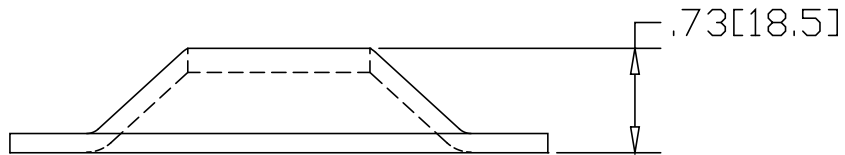

REV
SH
DWG NO 8045-NH

REVISIONS			
REV	DESCRIPTION	DATE	APPROVED

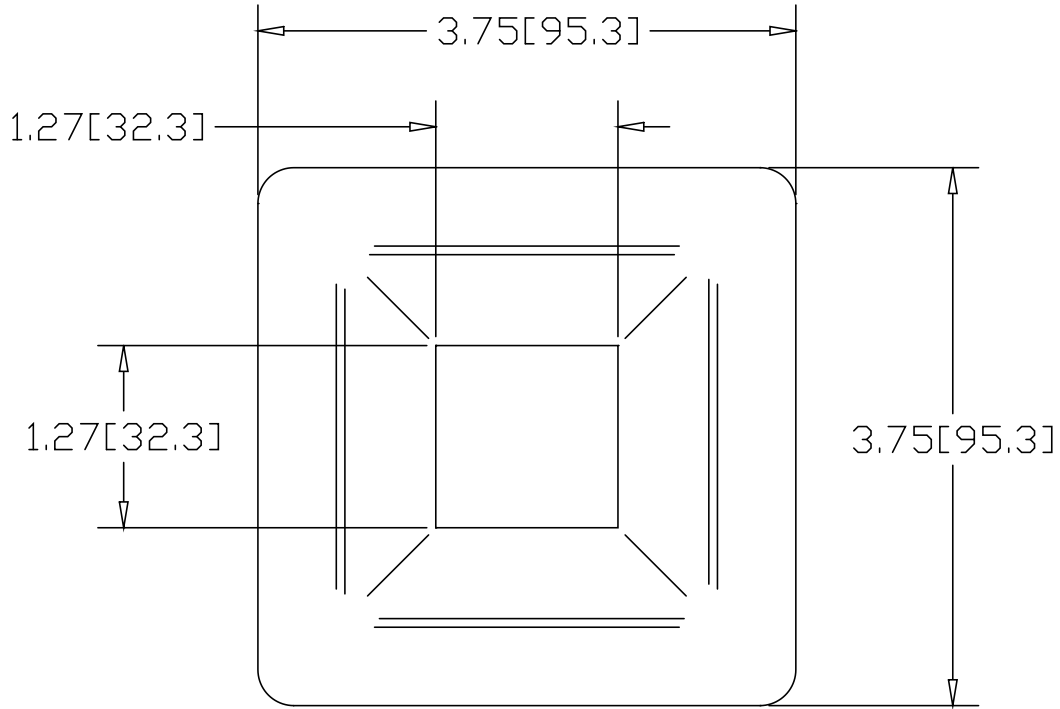

INCHES [MILLIMETERS]

ALTERNATE MATERIAL	PART NUMBER
.125 (3003) ALUMINUM ASTM B209	8046-NH

PART NAME		1.25" SQUARE TUBE FLANGE	
MATERIAL		10 GA. HRP&D STEEL ASTM A569	
DATE	7/24/96	 R & B WAGNER, INC.	
DRAWN BY	RJF		
FINISH	MILL	SIZE	A
		WEIGHT	.50 LBS
		PART NUMBER	8045-NH
		REV	