

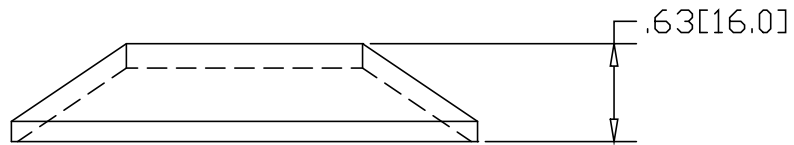

REV
SH
8089
DWG NO

REVISIONS			
REV	DESCRIPTION	DATE	APPROVED

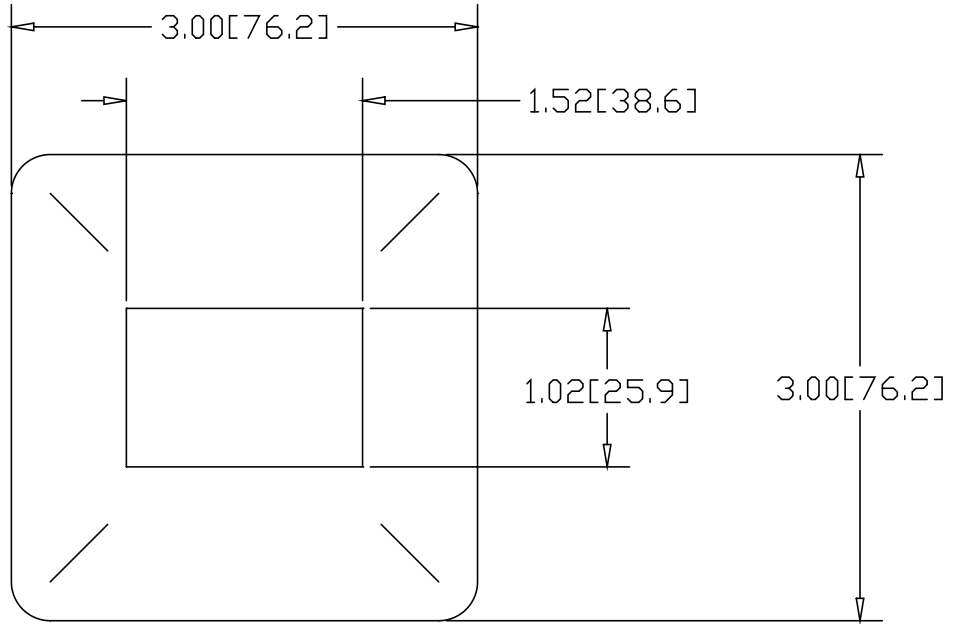

INCHES [MILLIMETERS]

ALTERNATE MATERIAL	PART NUMBER
.125 (3003) ALUMINUM ASTM B209	8090

PART NAME		1.50 X 1.00" RECTANGULAR POST COVER PLATE			
MATERIAL		10 GA. HRP&D STEEL ASTM A569			
DATE	9/17/96	 R & B WAGNER, INC.			
DRAWN BY	RJF				
FINISH	MILL	SIZE	WEIGHT	PART NUMBER	REV
		A	.33 LBS	8089	