

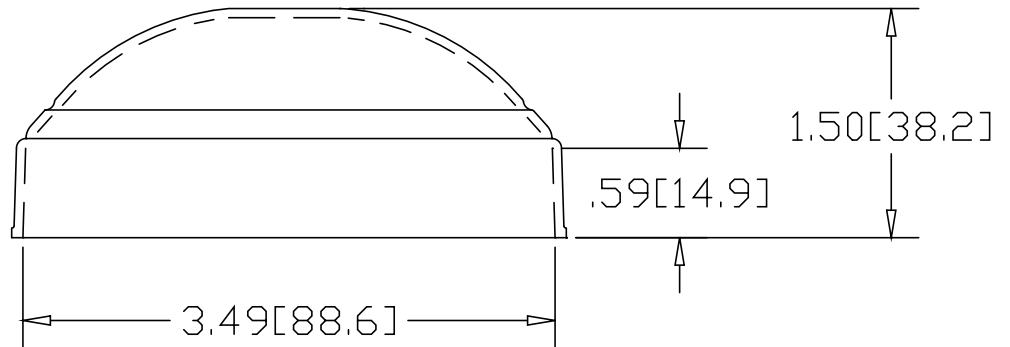

REV  
SH  
5112  
DWG NO

REVISIONS			
REV	DESCRIPTION	DATE	APPROVED

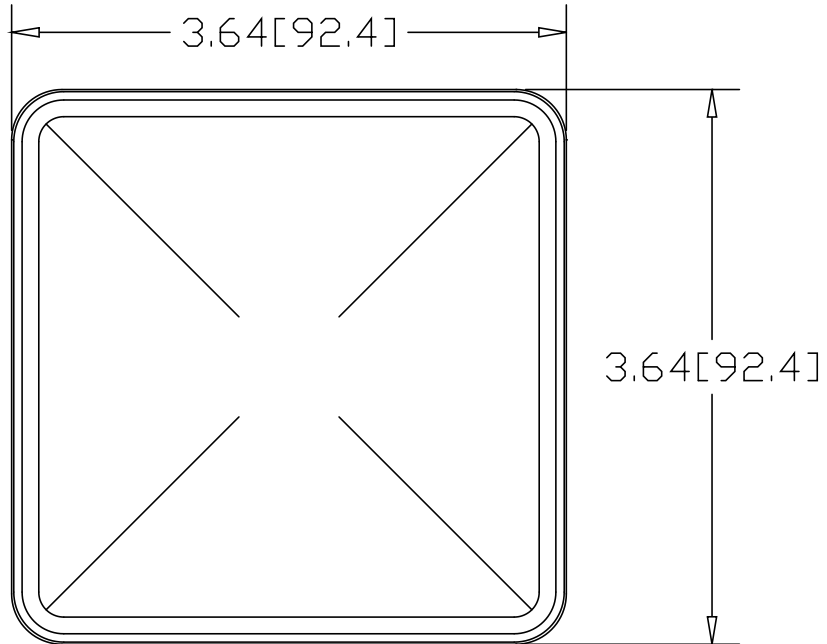

INCHES [MILLIMETERS]

ALTERNATE MATERIAL	PART NUMBER
.050 (3003) ALUMINUM ASTM B209	5113
18 GA. (304) STAINLESS STEEL ASTM A240	5115

PART NAME		3.50" SQUARE NEWEL POST CAP	
MATERIAL		18 GA. STEEL ASTM A-366	
DATE	10/26/93	 <b>THE WAGNER COMPANIES</b> R & B WAGNER, INC. AND J. G. BRAUN CO.	
DRAWN BY	RJF		
FINISH	MILL		
SIZE	WEIGHT	PART NUMBER	REV
A	.31 lbs	5112	