

REV
SH
1960
DWG NO

REVISIONS			
REV	DESCRIPTION	DATE	APPROVED

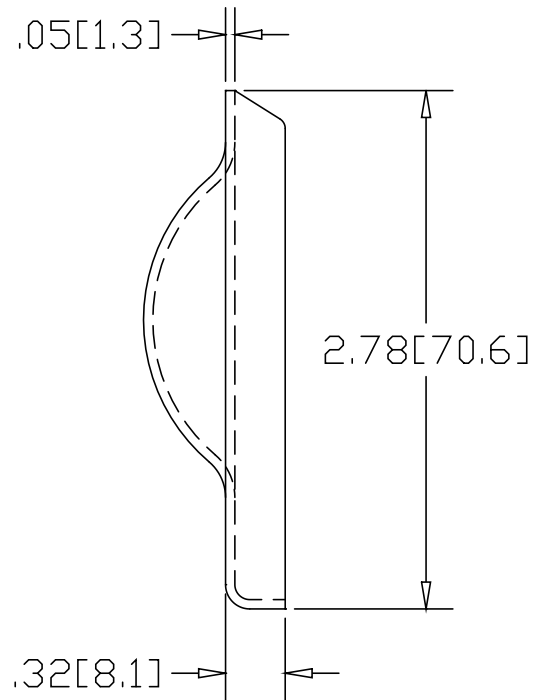
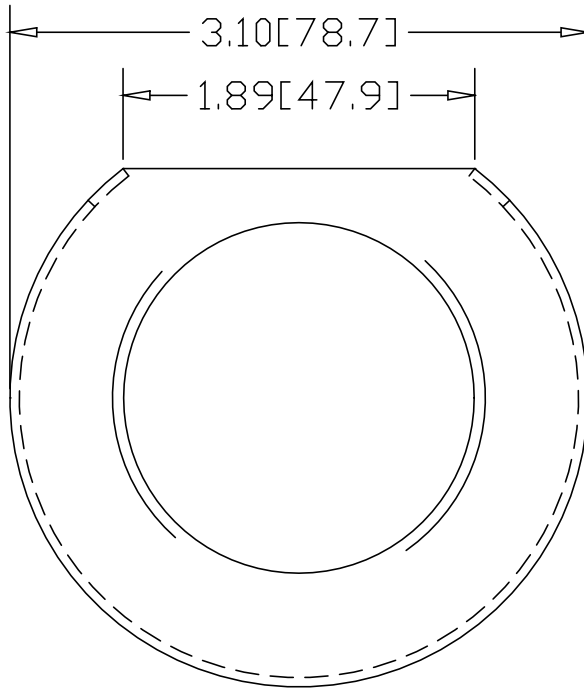

FITS 1 HOLE 1/4" BRACKETS
#1930 THRU #1959
(NOT FOR USE WITH 2 OR 3 HOLE BRACKETS)

INCHES [MILLIMETERS]

ALTERNATE MATERIAL	PART NUMBER
.050 (3003) ALUMINUM ASTM B209	1961
16 GA. (304) STAINLESS STEEL ASTM A240	1962
.050 (260) BRASS ASTM B19, B36	1963
.065 MUNTZ SHEET	1964

PART NAME CONCEALED MOUNT SNAP COVER FOR 1-HOLE 1/4" BRACKETS			
MATERIAL 16 GA. STEEL ASTM A366			
DATE 6/10/96	 R & B WAGNER, INC.		
DRAWN BY RJF			
FINISH MILL	SIZE A	WEIGHT .11 LBS	PART NUMBER 1960
			REV