

NOTE:
SEE SHEET 2 FOR SUPPLIER PRINT AND APPROVED DIMENSIONS

REVISION HISTORY			
REV	DESCRIPTION	DATE	APPROVED
1	REMOVED LOWER LEG REVISED AND REDRAWN IN CAD	1/23/2020	AHS

TOLERANCE UNLESS OTHERWISE NOTED, TOLERANCES TO CONFORM TO ES.03.011	CUT LENGTH:	FINISH:	DESCRIPTION: Gasket, Plastic, Glass Rail, Insert For Top of PanelGrip Shoe Mouldings, Black	
		Mill	MATERIAL: z-Rubber	MATERIAL DESC: Rubber
	DEVELOPED LENGTH:	WEIGHT:	DATE: 1/23/2020	REV: 1
		0.10 lbmass	DRAWN BY: K. Turdo	PART NUMBER: GR9355
	TOOL NUMBER:		10600 W Brown Deer Rd Milwaukee, WI 53224 COLLABORATIVE METALWORKS http://www.wagnercompanies.com/	



DENSE RUBBER		
ASPM CLASS 2 TABLE 1		
DIMENSIONS (in) ISO-E 2015		
Above	Up To	Tolerance
0.000	0.050	±0.010
0.061	0.100	0.014
0.101	0.160	0.016
0.161	0.250	0.020
0.251	0.390	0.027
0.391	0.630	0.031
0.631	0.980	0.039
0.981	1.570	0.051
1.571	2.480	0.063
2.481	3.940	0.070

See 2.26 for dimensions over 250 inches.

I have inspected this drawing submitted by Cooper Standard ISG, and approve/validate the design, dimensions, and tolerances.

[Signature] 11-19-19
 Signature Date

NO	REVISIONS	DATE	BY	ECN#

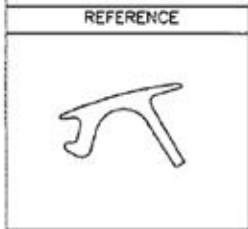
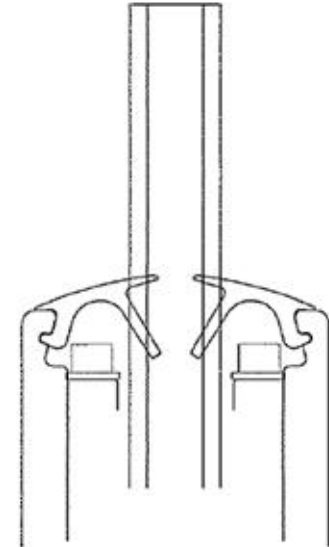
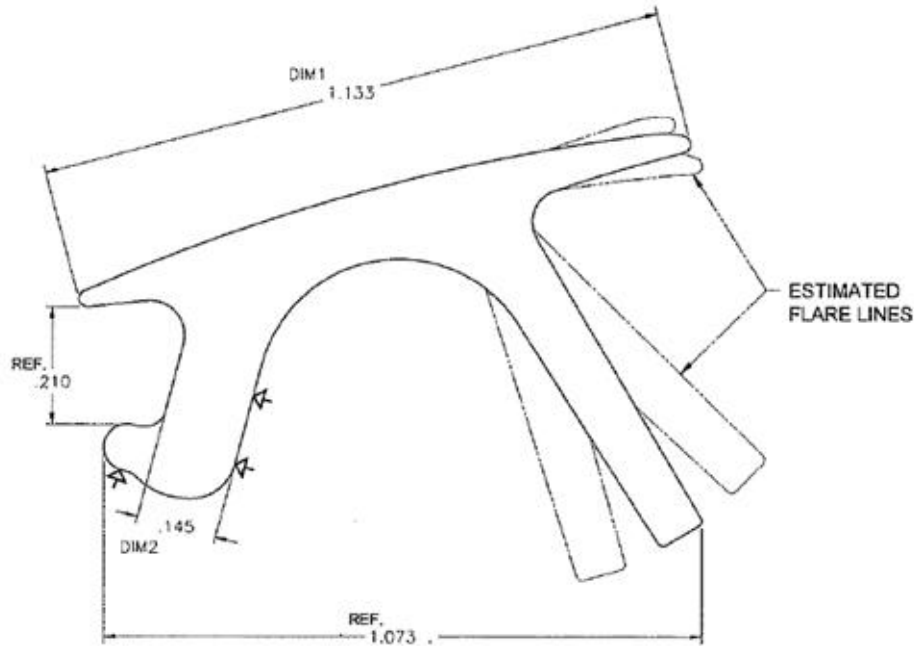

****DO NOT SCALE DRAWING****

CooperStandard
INDUSTRIAL AND SPECIALTY

CONFIDENTIAL AND PROPRIETARY INFORMATION. THIS DRAWING AND ALL OF THE INFORMATION CONTAINED HEREIN IS OWNED SOLELY BY COOPER STANDARD ISG WHICH RESERVES ALL THE RIGHTS TO THIS INFORMATION, REPRODUCTION, PUBLICATION, DISTRIBUTION, AND/OR DISSEMINATION OF THIS INFORMATION, IN WHOLE, OR IN PART, IS PROHIBITED WITHOUT WRITTEN AUTHORIZATION FROM COOPER-STANDARD ISG.

DESIGN BY: LMW DATE: 11/15/19
 CUSTOMER: R&B WAGNER INC
 PROGRAM / PROJECT: GR9355 REDESIGN
 CUSTOMER P/N:
 MATERIAL: 70 DURO DENSE EPDM (BLACK)
 MATERIAL SPECIFICATION: ASTM D 2000
 FINISHING REF: DRAWING NO: 56373
 SHEET 1 NO. 1

UNITS = INCH [MM]

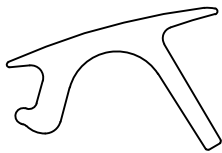

TOLERANCE UNLESS OTHERWISE NOTED, TOLERANCES TO CONFORM TO ES.03.011	CUT LENGTH:	FINISH:	DESCRIPTION: Gasket, Plastic, Glass Rail, Insert For Top of PanelGrip Shoe Mouldings, Black	
		Mill	MATERIAL:	MATERIAL DESC:
	DEVELOPED LENGTH:	WEIGHT:	z-Rubber	Rubber
		0.10 lbmass	DATE: 1/23/2020	REV: 1
	TOOL NUMBER:		DRAWN BY: K. Turdo	
			PART NUMBER: GR9355	

WAGNER 10600 W Brown Deer Rd
 Milwaukee, WI 53224
 COLLABORATIVE METALWORKS <http://www.wagnercompanies.com/>

