

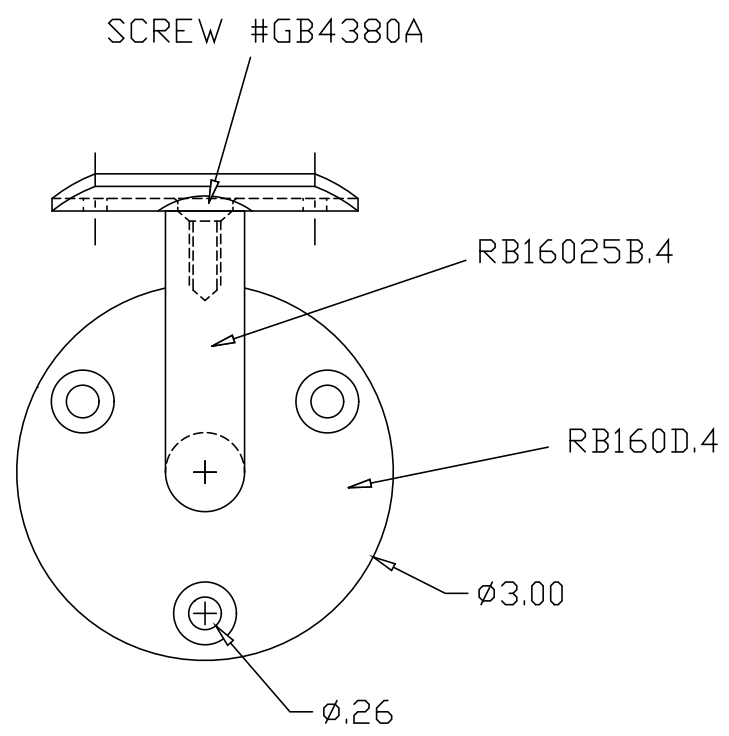

REVISIONS			
REV	DESCRIPTION	DATE	APPROVED

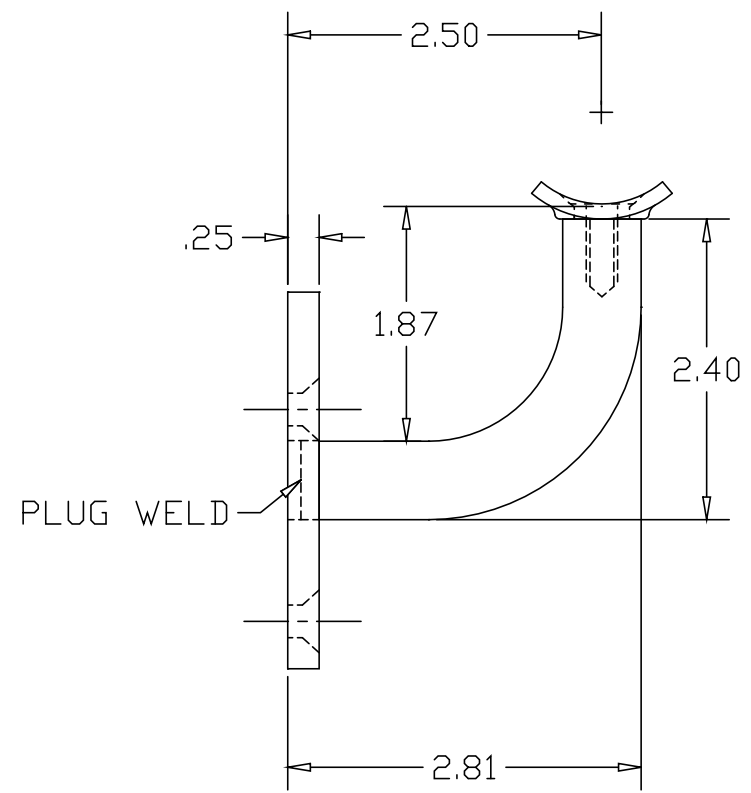

PART NAME		HANDRAIL BRACKET, BAR BEND FABRICATED		
MATERIAL		360 BRASS		
DATE	03/06/09		<b>THE WAGNER COMPANIES</b> R & B WAGNER, INC. AND J. G. BRAUN CO.	
DRAWN BY	RDC			
FINISH	#4 SATIN	SIZE	WEIGHT	PART NUMBER
		A		RB16025.4
				REV