

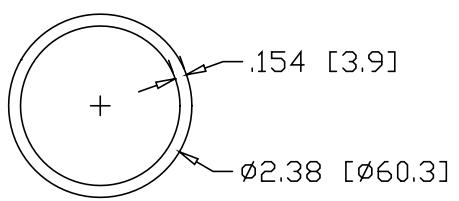

REV  
SH  
5728  
DWG NO

REVISIONS			
REV	DESCRIPTION	DATE	APPROVED

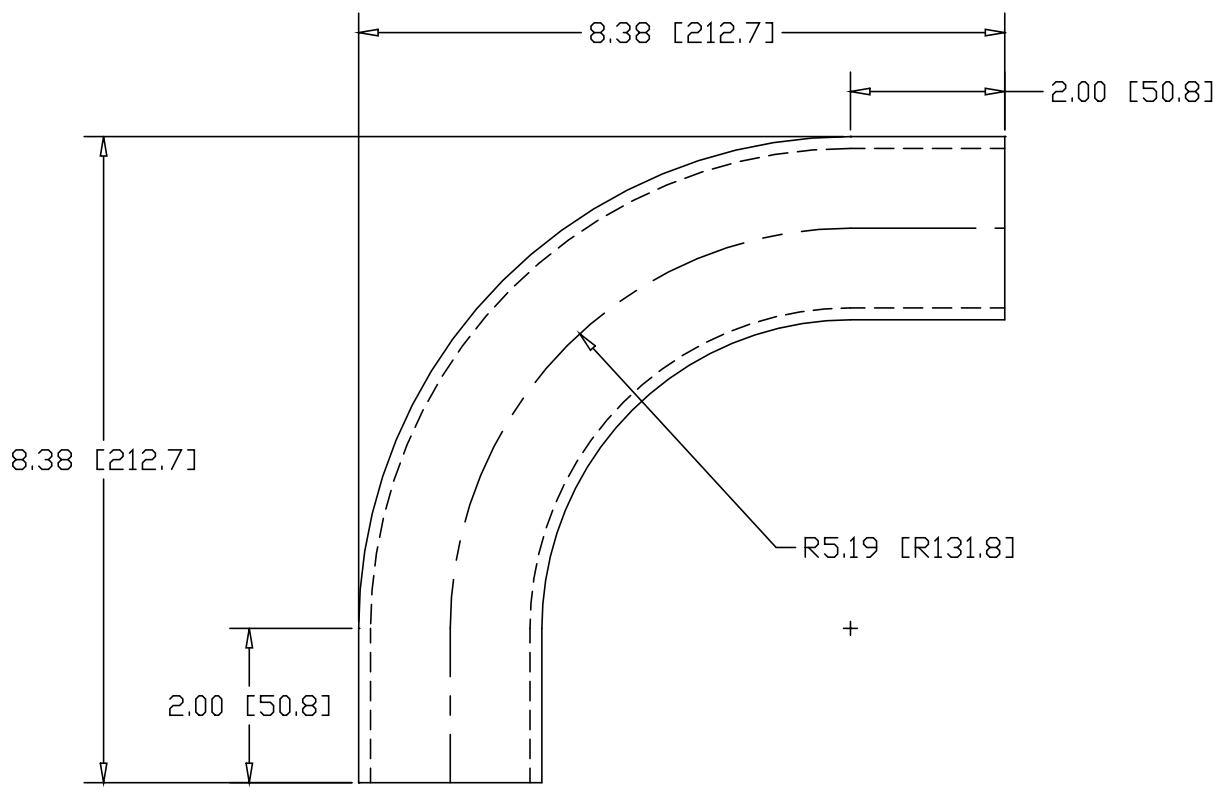

INCHES [MILLIMETERS]

ALTERNATE MATERIAL	PART NUMBER
2" SCH 40 (6063) ALUMINUM PIPE	5742
2" SCH 40 (304) STAINLESS STEEL PIPE	5756

PART NAME 2" PIPE SIZE 90° X 4" I.R. ELL W/(2) 2" TANGENTS			
MATERIAL 2" SCH 40 STEEL PIPE			
DATE 4/9/96		R & B WAGNER, INC.	
DRAWN BY RJF		FINISH MILL	SIZE A
		PART NUMBER 5728	REV