

REV
SH
3684A
DWG NO

REVISIONS			
REV	DESCRIPTION	DATE	APPROVED

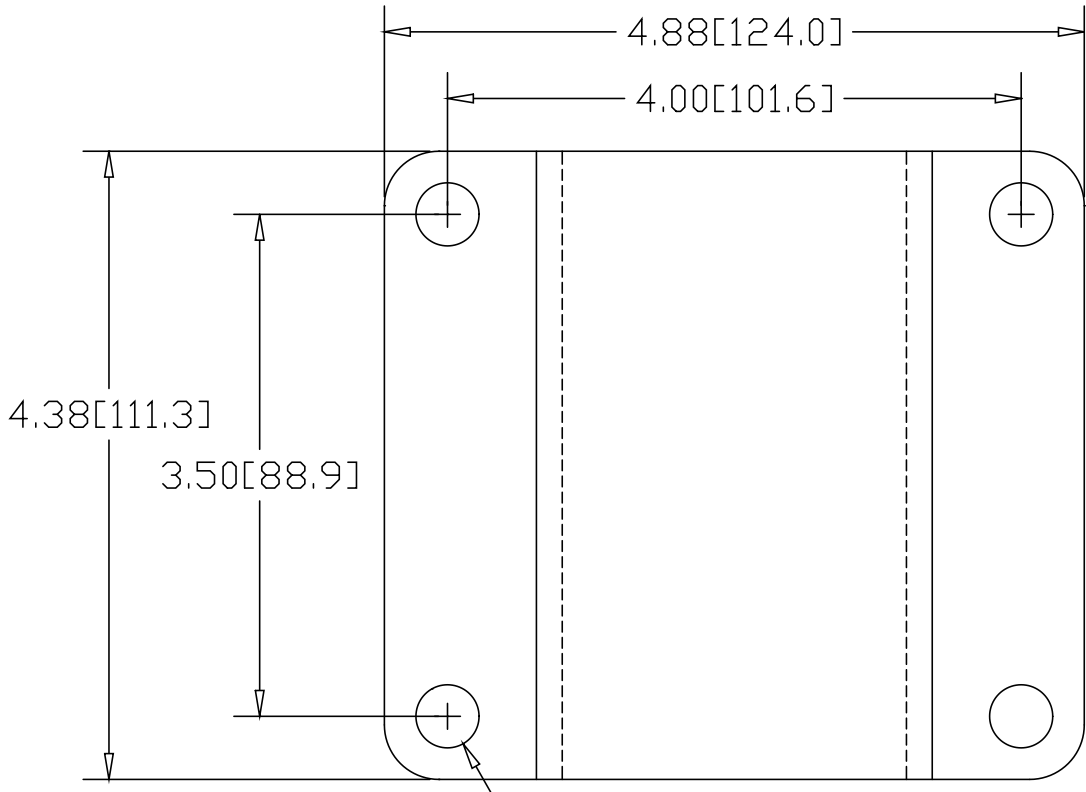

Ø.44 [Ø11.2] TYP

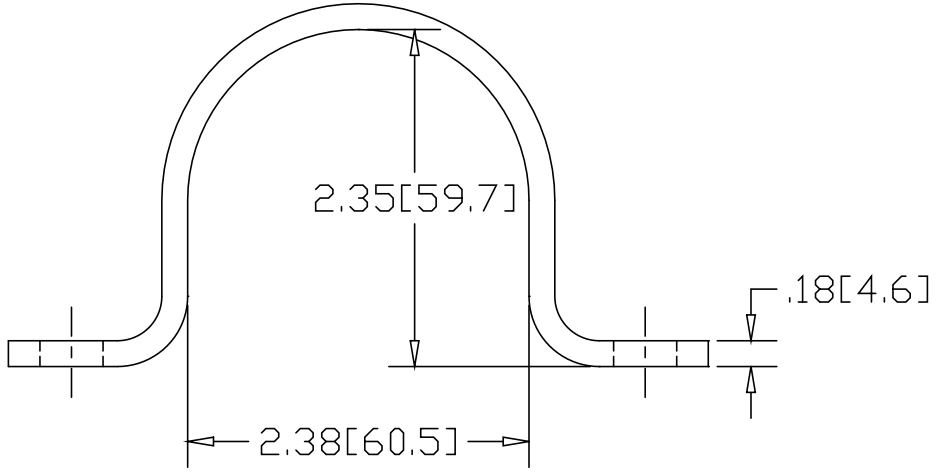

INCHES [MILLIMETERS]

ALTERNATE MATERIAL	PART NUMBER
.190 (3003) ALUMINUM ASTM B209	3685A
7 GA. (304) STAINLESS STEEL ASTM A240	3685-SS

PART NAME 2" PIPE X 4.38" WIDE U-BRACKET W/(4) HOLES				
MATERIAL 7 GA. HRP&D STEEL ASTM A569				
DATE 02/11/00	 THE WAGNER COMPANIES R & B WAGNER, INC. AND J. G. BRAUN CO.			
DRAWN BY RJF		SIZE A	WEIGHT 1.77 LBS	PART NUMBER 3684A
FINISH MILL				REV