

REV

SH

1422T

DWG NO

REVISIONS

REV	DESCRIPTION	DATE	APPROVED

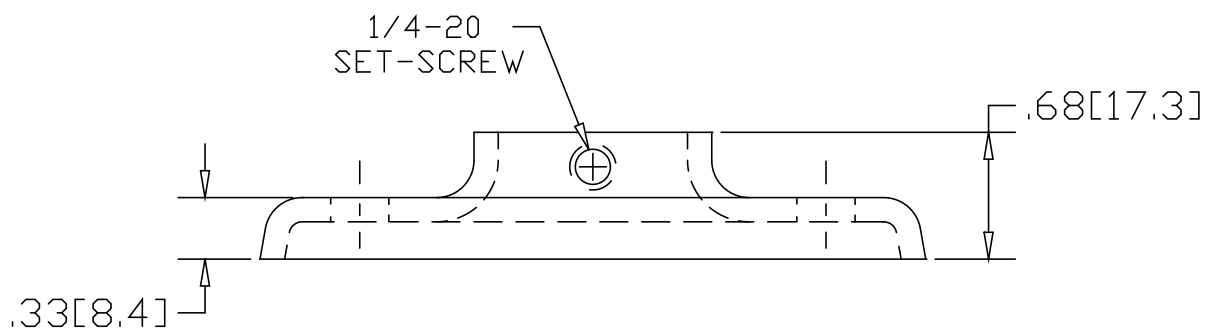
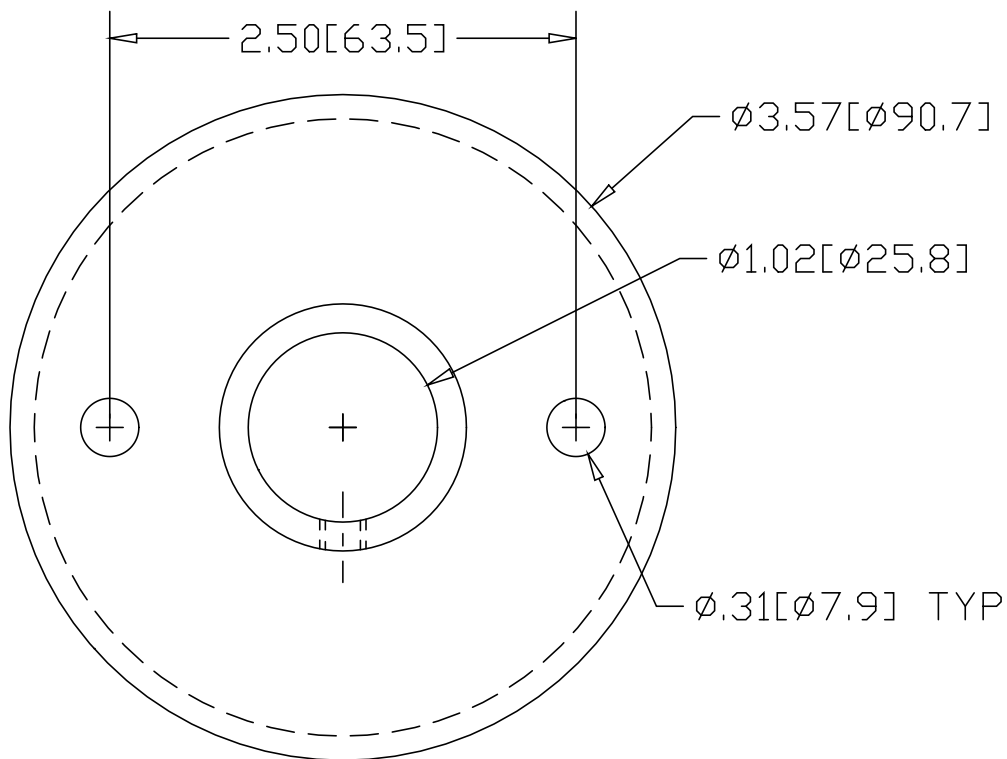

INCHES [MILLIMETERS]

ALTERNATE MATERIAL	PART NUMBER
.125 (3003) ALUMINUM ASTM B209	1462T
10 GA. (304) STAINLESS STEEL ASTM A240	1522T

PART NAME 1" OD TUBE HEAVY BASE FLANGE W/⟨2⟩ HOLES AND SET-SCREW			
MATERIAL 10 GA. HRP&D STEEL ASTM A569			
DATE 9/13/94	 R & B WAGNER, INC.		
DRAWN BY RJF			
FINISH MILL	SIZE A	WEIGHT .41 LBS	PART NUMBER 1422T
			REV