

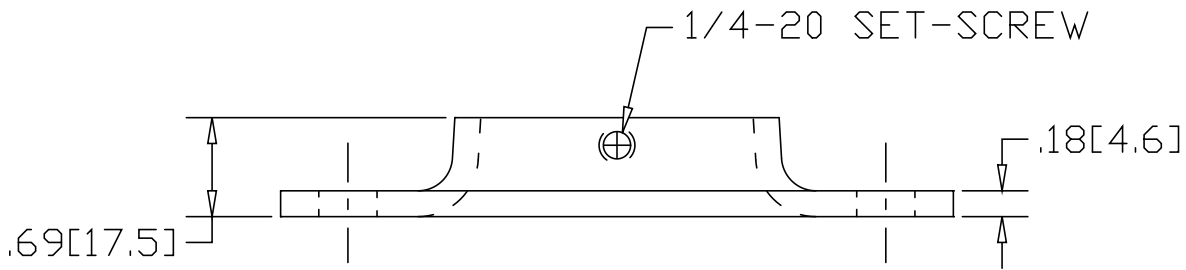

REV
SH
1625
DWG NO

REVISIONS			
REV	DESCRIPTION	DATE	APPROVED

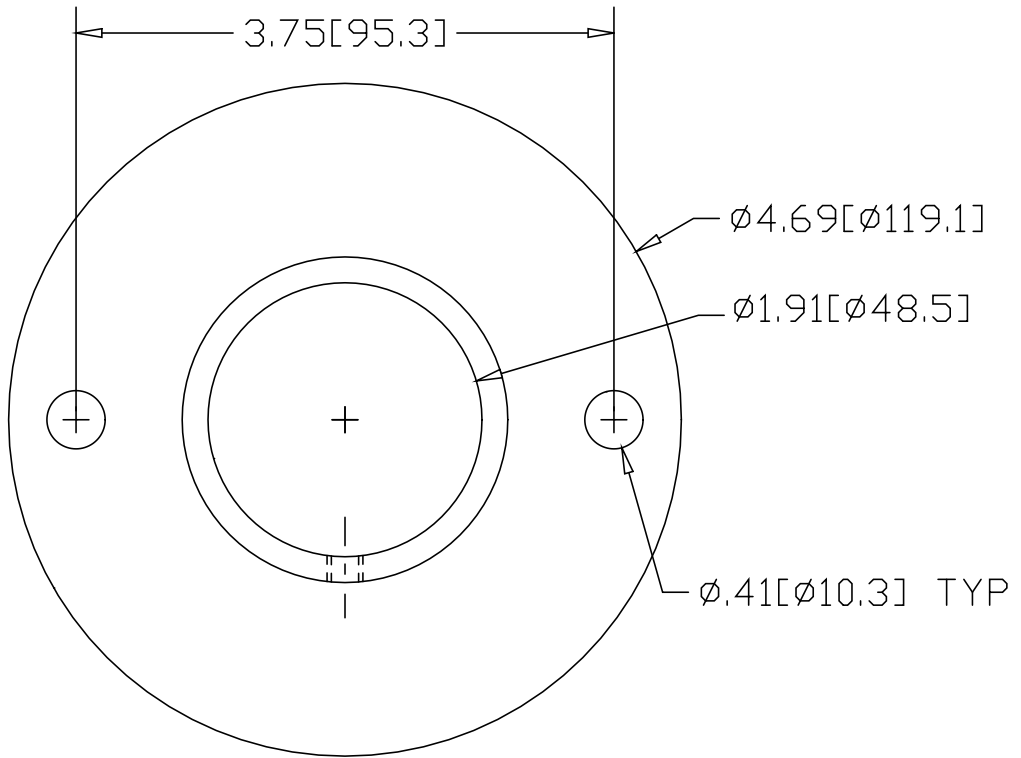

INCHES [MILLIMETERS]

ALTERNATE MATERIAL	PART NUMBER
.190 (3003) ALUMINUM ASTM B-209	1645

PART NAME 1-1/2" PIPE SIZE EXTRA HEAVY FLANGE W/⟨2⟩ HOLES & SET-SCREW				
MATERIAL 7 GA. HPR&D STEEL ASTM A-569				
DATE 3/2/95		R & B WAGNER, INC.		
DRAWN BY RJF		FINISH MILL	SIZE A	WEIGHT .81 LBS
		PART NUMBER	1625	REV