

REV
SH
2543
DWG NO

REVISIONS			
REV	DESCRIPTION	DATE	APPROVED

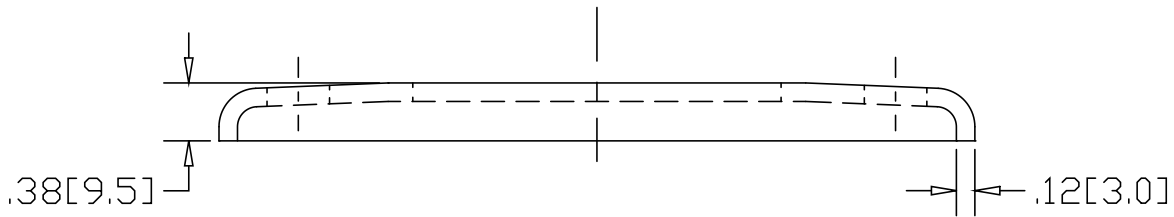
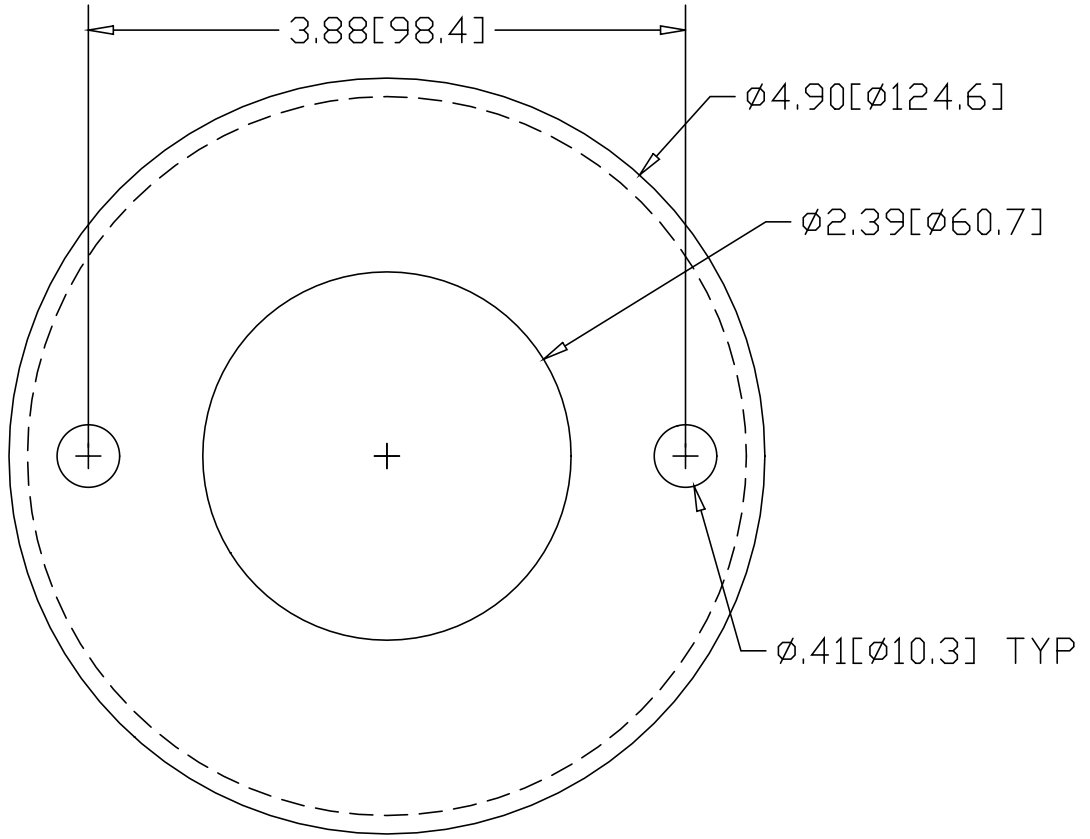

INCHES [MILLIMETERS]

*USE WITH ANCHOR PLATE
 #B1448 IN STEEL
 #PLB1448 ZINC PLATED STEEL
 #B1548 IN STAINLESS

ALTERNATE MATERIAL	PART NUMBER
.125 (3003) ALUMINUM ASTM B209	2583
10 GA. (304) STAINLESS STEEL ASTM A240	2623

PART NAME 2" PIPE HEAVY FLUSH BASE FLANGE W/(2) HOLES			
MATERIAL 10 GA. HRP&D STEEL ASTM A569			
DATE 4/5/99		R & B WAGNER, INC.	
DRAWN BY RJF		FINISH MILL	SIZE A
PART NUMBER 2543		REV	