

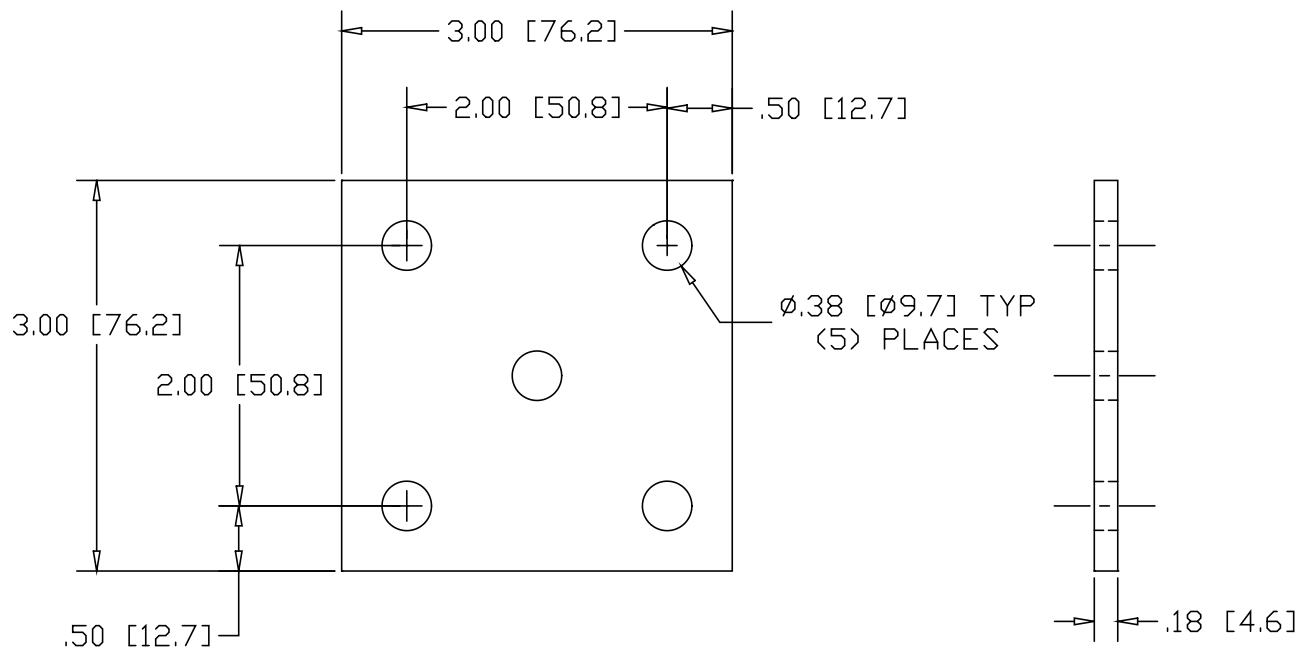

REV
SH
31
DWG NO

REVISIONS			
REV	DESCRIPTION	DATE	APPROVED



INCHES [MILLIMETERS]

ALTERNATE MATERIAL	PART NUMBER
7 GA. HRP&D STEEL ASTM A569 ZINC PLATED	31P
.190 3003 ALUMINUM ASTM B209	32

PART NAME		BASE PLATE	
MATERIAL		7 GA. HRP&D STEEL ASTM A569	
DATE	8/15/03	 THE WAGNER COMPANIES R & B WAGNER, INC. AND J. G. BRAUN CO.	PART NUMBER 31
DRAWN BY	RJF		
FINISH	MILL		
SIZE	A	WEIGHT	.383 LBS
		REV	

