

REV  
SH  
8357  
DWG NO

REVISIONS			
REV	DESCRIPTION	DATE	APPROVED

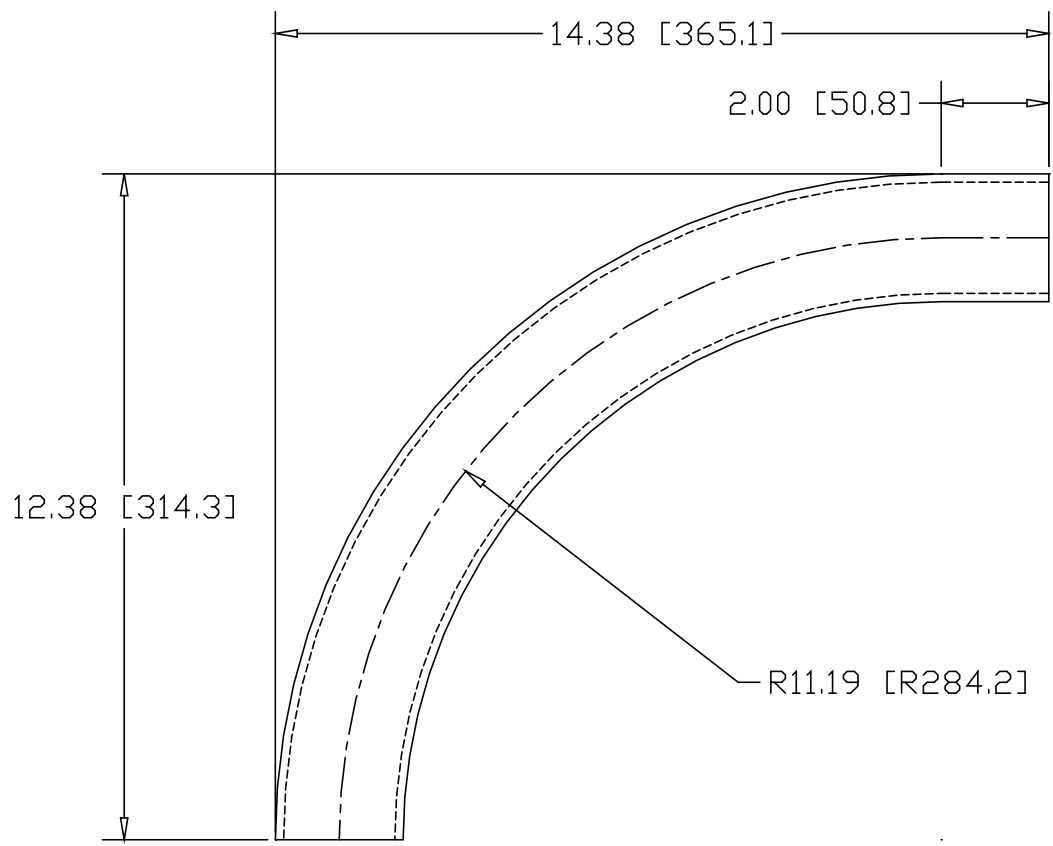

INCHES [MILLIMETERS]

ALTERNATE MATERIAL	PART NUMBER
2" SCH 40 (6063) ALUMINUM PIPE	8371
2" SCH 40 (304) STAINLESS STEEL PIPE	8385

PART NAME 2" PIPE SIZE 90° ELL X 10" I.R. W/ (1) 2" TANGENT			
MATERIAL 2" SCH 40 A53 STEEL PIPE			
DATE 8/7/01	<b>WAGNER</b>	R & B WAGNER, INC.	
DRAWN BY JAH			
FINISH MILL			
SIZE A	WEIGHT 5.92 LBS	PART NUMBER 8357	REV