

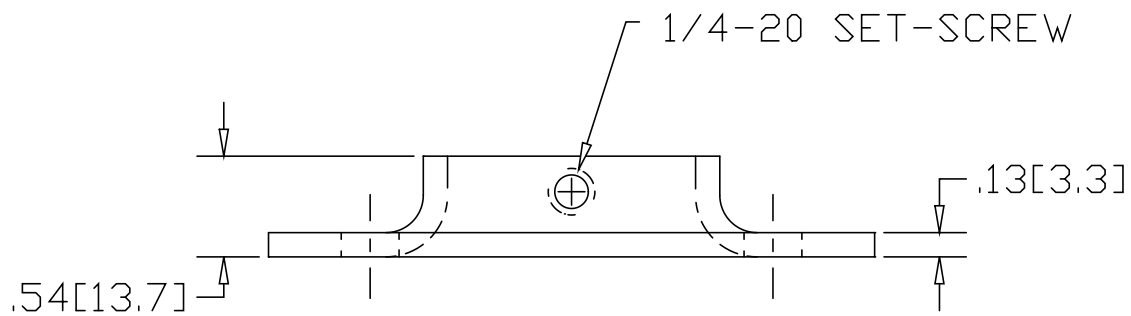

REV  
SH  
630AT  
DWG NO

REVISIONS			
REV	DESCRIPTION	DATE	APPROVED

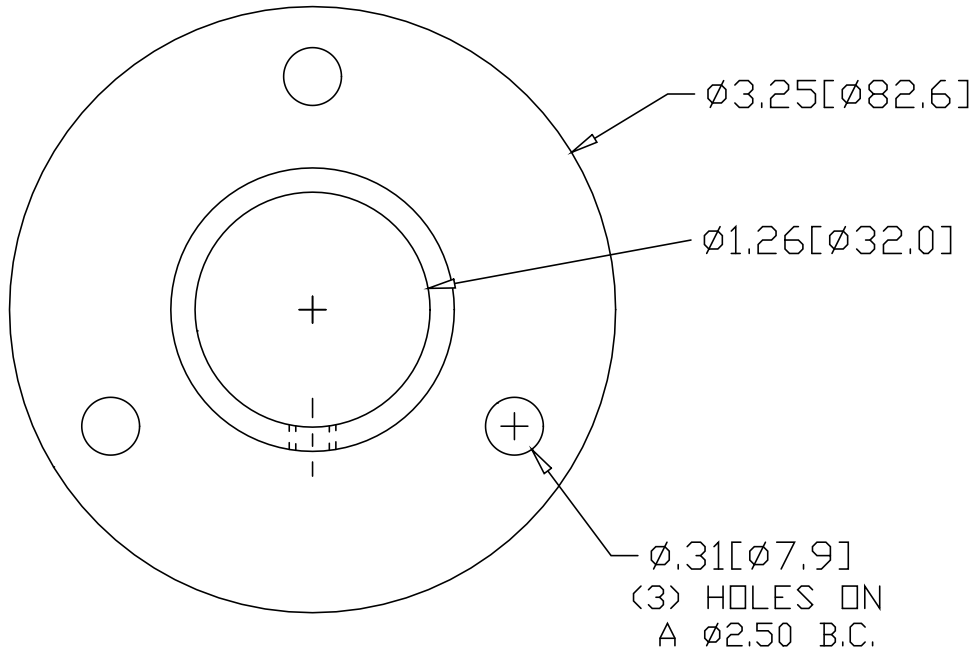

INCHES [MILLIMETERS]

ALTERNATE MATERIAL	PART NUMBER
.125 (3003) ALUMINUM ASTM B209	670AT
10 GA. (304) STAINLESS STEEL ASTM A240	710AT

PART NAME 1-1/4" O.D. TUBE FLAT BASE FLANGE W/(3) HOLES AND SET-SCREW				
MATERIAL 10 GA. HRP&D STEEL ASTM A-569				
DATE 1/11/99		R & B WAGNER, INC.		
DRAWN BY RJF		FINISH MILL	SIZE A	WEIGHT .3 LBS
		PART NUMBER	630AT	REV