

REV  
SH  
2527A  
DWG NO

REVISIONS			
REV	DESCRIPTION	DATE	APPROVED

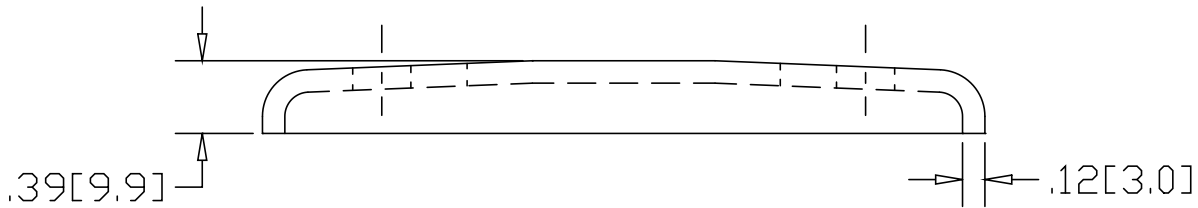
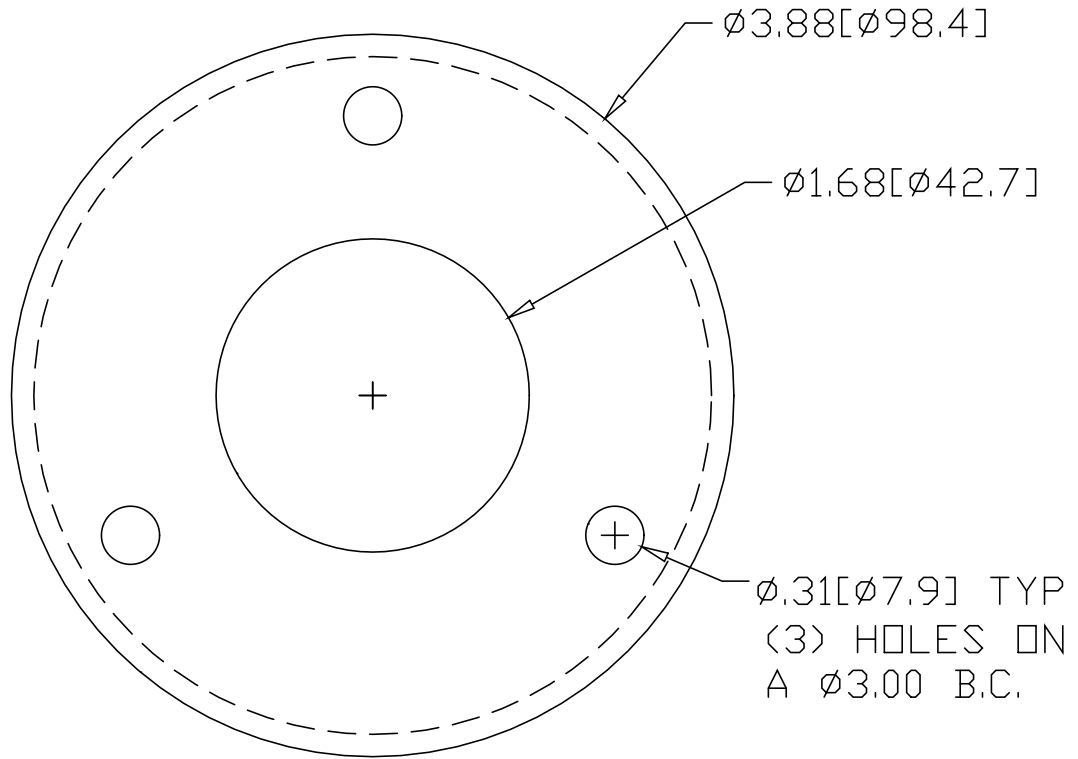

INCHES [MILLIMETERS]

\*USE WITH ANCHOR PLATE  
 #B1432 IN STEEL  
 #PLB1432 ZINC PLATED STEEL  
 #B1532 IN STAINLESS STEEL

ALTERNATE MATERIAL	PART NUMBER
.125 (3003) ALUMINUM ASTM B209	2567A
10 GA. (304) STAINLESS STEEL ASTM A240	2607A

PART NAME 1-1/4" PIPE HEAVY FLUSH BASE FLANGE W/(3) HOLES			
MATERIAL 10 GA. HRP&D STEEL ASTM A569			
DATE 3/31/99		R & B WAGNER, INC.	
DRAWN BY RJF		FINISH MILL	SIZE A
		PART NUMBER 2527A	REV