

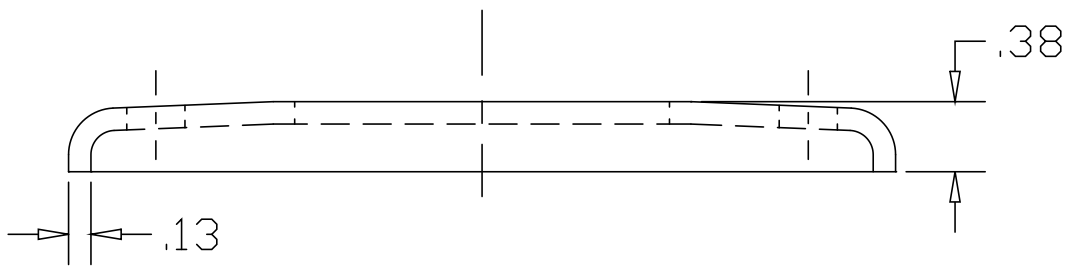

REV
SH
2843T
DWG NO

REVISIONS			
REV	DESCRIPTION	DATE	APPROVED

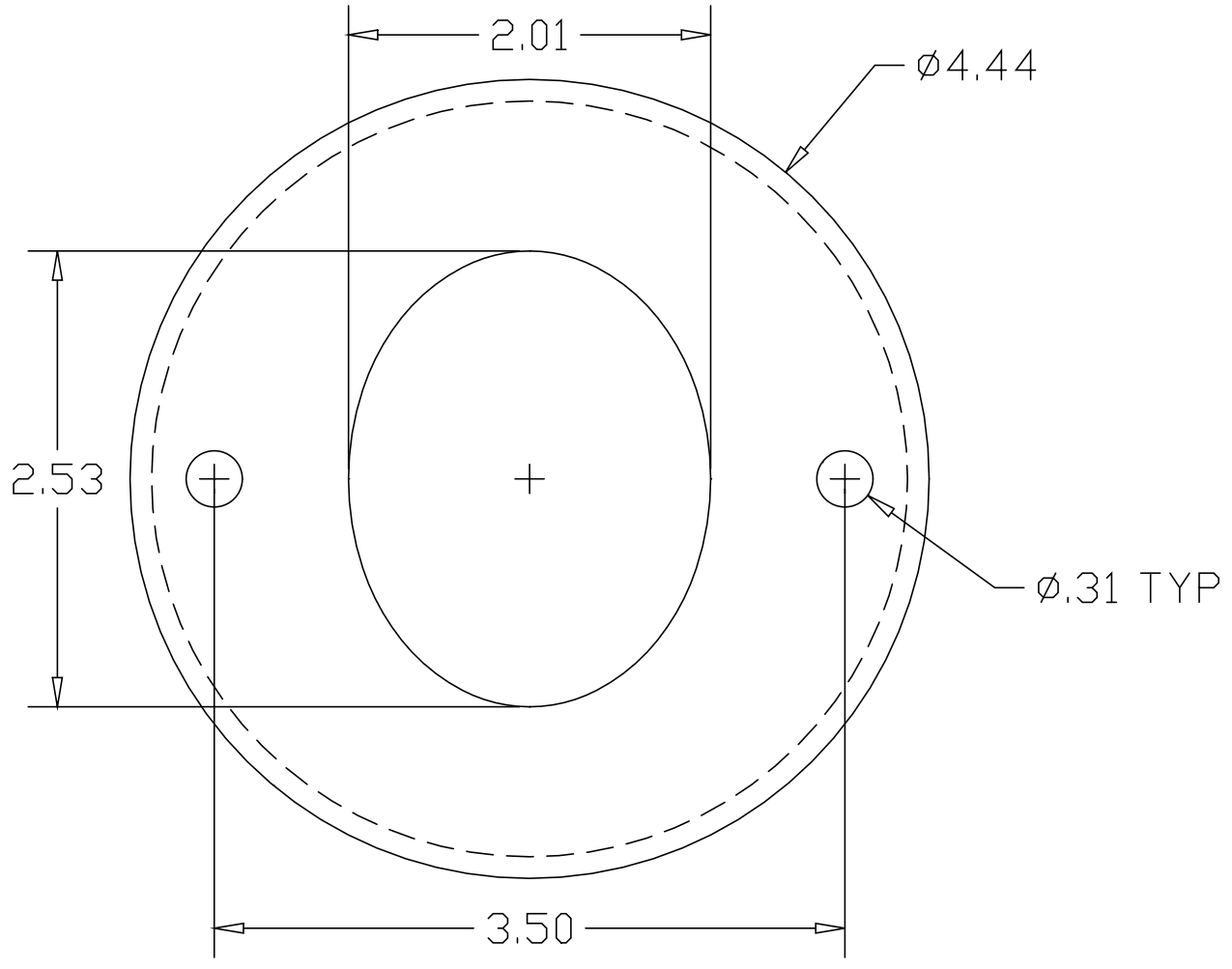

PART NAME 2" O.D. TUBE HEAVY FLUSH BASE BEVELED FLANGE W/(2) HOLES			
MATERIAL 10 GA. HRP&D STEEL ASTM A569			
DATE 9/6/94		THE WAGNER COMPANIES R & B WAGNER, INC. AND J. G. BRAUN CO.	
DRAWN BY RJF			
FINISH MILL	SIZE A	WEIGHT .63 LBS	PART NUMBER 2843T
			REV