

TEST SAMPLE DESCRIPTION

Wagner Part Number: GRTLSF96S

1.1 General

Product Code/Name	TLSF96-12
Test Requirements	STRUCTURAL PERFORMANCE (A) E2353-16 E2358-17
Date of Test	19/09/2019

1.2 Barrier/Glass

Glass Make Up	12mm Toughened Glass
Glass Panel Size	Height - 1300mm Width - 1200mm
Overall Size	Height - 1070mm Width - 1200mm
Handrail Used	No Handrail

1.3 Spigot System: TLSF96

Material	Stainless Steel 2205 Duplex
Overall Size	155mmH x 48mmW
Drawing Supplied	Yes
Fixing Method	M10 316 stainless steel bolt

PRODUCT TEST REPORT

Wagner Part Number: GRTLSF96S

PTY LTD

DATE: 18/09/2019		PRODUCT NUMBER: TLSF96		HAND RAIL TYPE: N/A	
GLASS TYPE	12mm Toughened Glass				
GLASS SIZE	1300mmHx1200mmW				
TEST METHOD	Concentrated, Uniform, Infill, loading applied with hydraulic ram				
FIXING TYPE, CENTRES	Spigots were 240mm in from each end (20%)				
TEMPERATURE	20.6°C				
HUMIDITY	59%				
RESULTS					
Type	Structural Performance	Deflection	Residual	Time U/L	
I-III	Concentrated Load on Rail: 890N Uniform Linear Load on Rail: 290N/m Infill Horizontal Load: 220N				
I-IV	Concentrated Load on Rail: 890N Uniform Linear Load on Rail: 730N/m Infill Horizontal Load: 220N				
I-V	Concentrated Load on Rail: 1330N Uniform Linear Load on Rail: 730N/m Infill Horizontal Load: 220N	108.3mm	2.72mm	60sec	
		57.33mm	1.31mm	60sec	
		19.85mm	0mm	60sec	
I-VI	Concentrated Load on Rail: 1620N Uniform Linear Load on Rail: 880N/m Infill Horizontal Load: 220N				
Notes:					
<p>The Uniform Linear Load was multiplied by 1.2 as we tested with a 1200mm wide panel of glass. The total loading for this test was 730N x 1.2 = 876N</p>					



WAGNER[®]

Employee Owned

GLASS HARDWARE SYSTEMS

Date: 18/09/2019

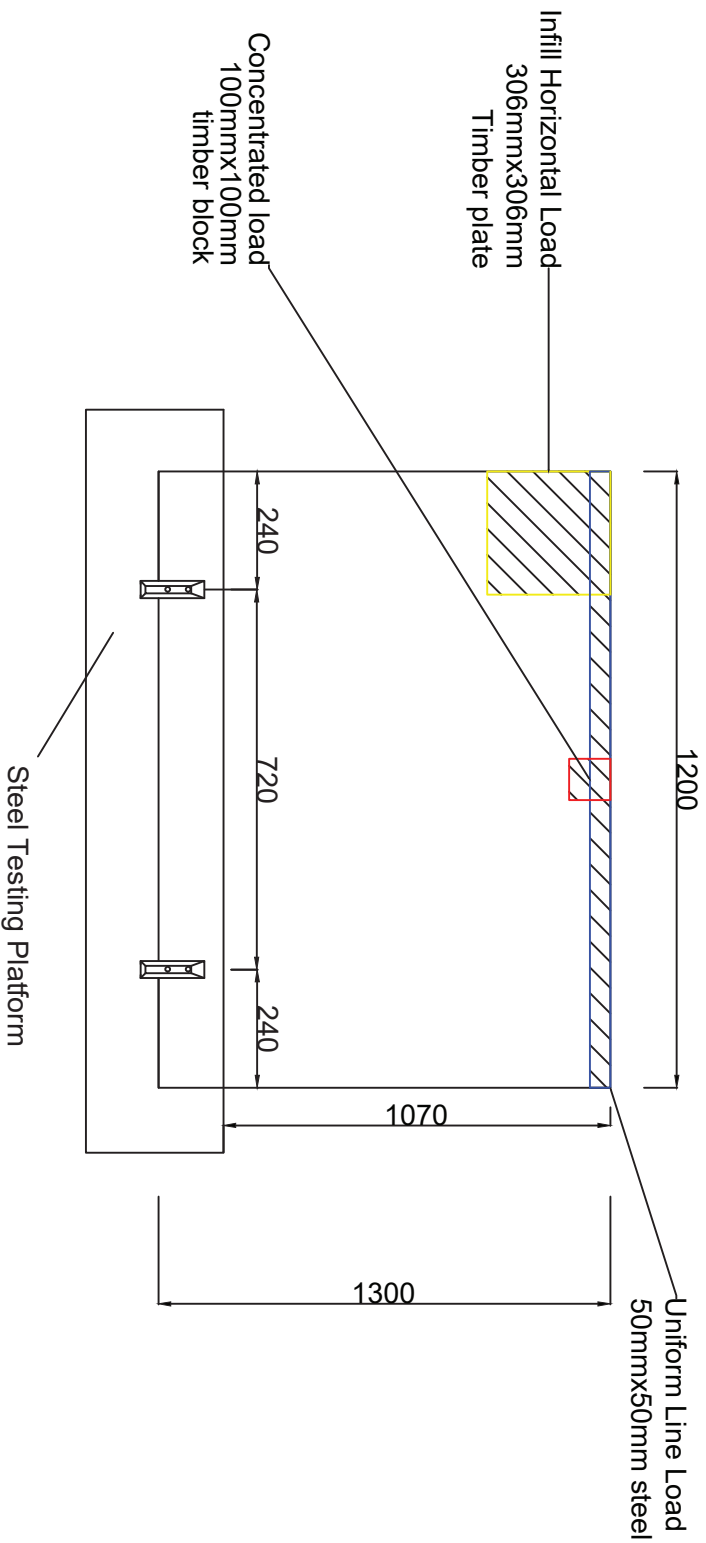

Part no: TLSF96 Glass Type: 12mm Toughened Glass

Material: 2205 Duplex Scale:

Fasteners used for testing: 316L SS M10 Bolts

2



1

BILL OF MATERIALS			
ITEM	PART NO.	DESCRIPTION	QTY.
1	TLSF82-SN	MOUNTING NUT	2
2	TLSF96-01	SPIGOT BODY	1
3	M12X18	GRUB SCREW	1
4	M12X18	GRUB SCREW	1
5	TL7240SSPI	PRESSURE PLATE	1
6	TL7240PI	GLASS ISOLATOR	1
7	TL7240PL	GLASS ISOLATOR	1
8	TL7240SSPL	ROCKER PLATE	1

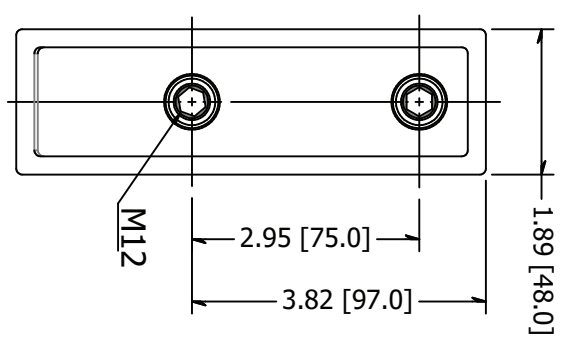
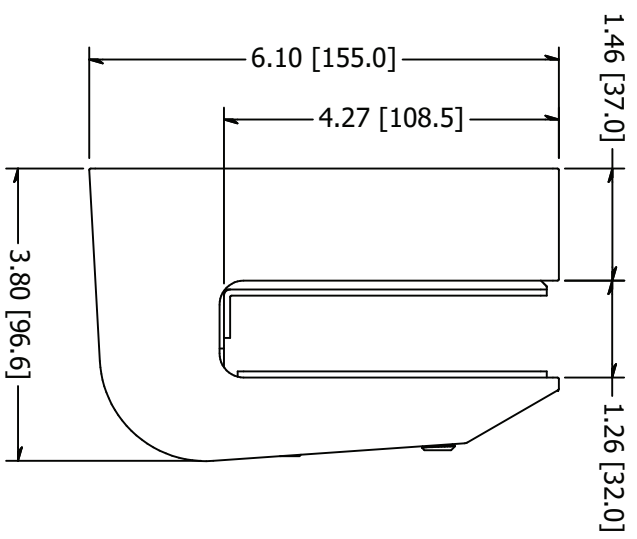
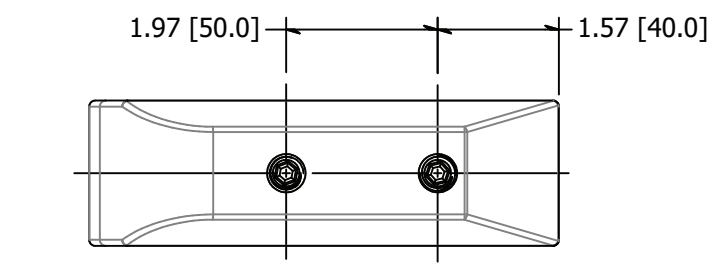
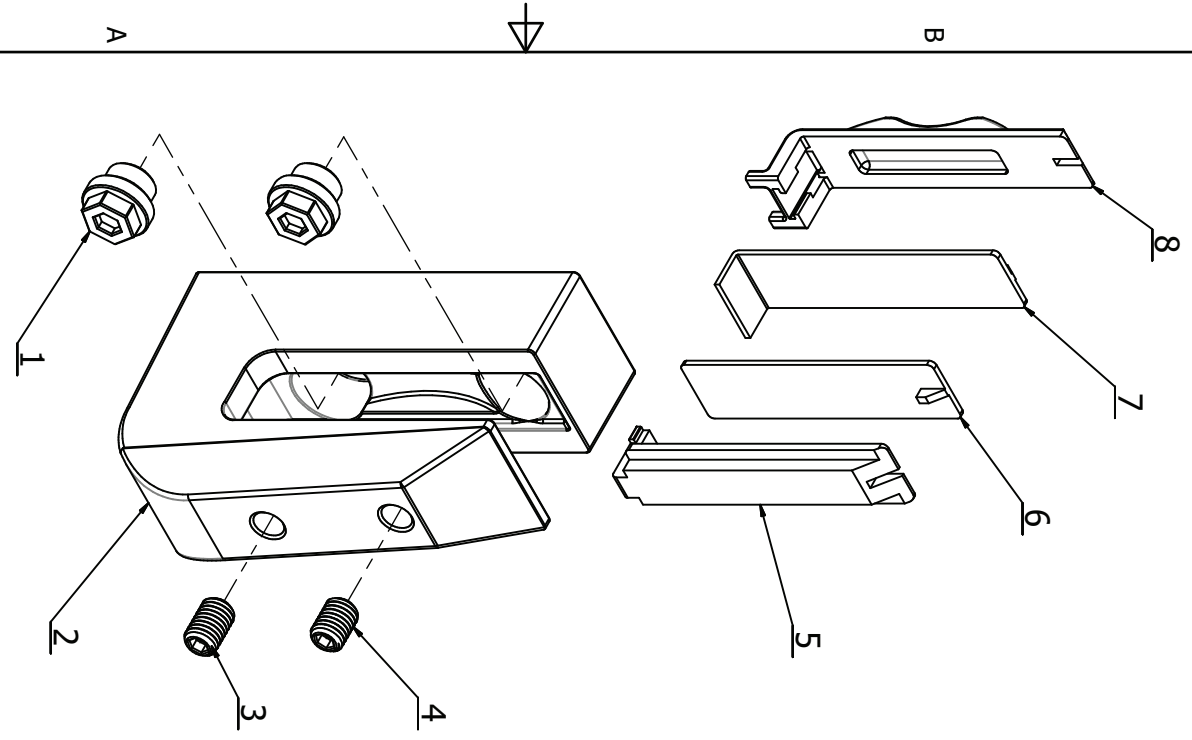
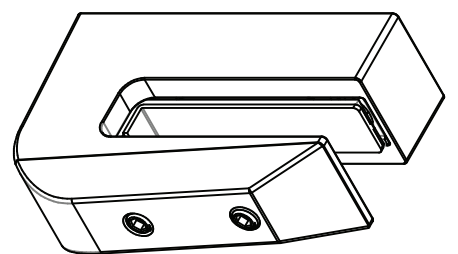

2



1

MATERIAL: 2205 SSTL	DESCRIPTION: Spigot, Level Lock, Center Concealed, For 12-25 52mm Glass, 6.1" High by 1.88" Wide
FINISH: #4	DATE: 11/11/2019
WEIGHT:	ITEM NUMBER: GRTLSP96S
	SCALE: REV:

WAGNER ARCHITECTURAL SYSTEMS
10600 W Brown Deer Rd
Milwaukee, WI 53224
<http://www.wagnercompanies.com/>