

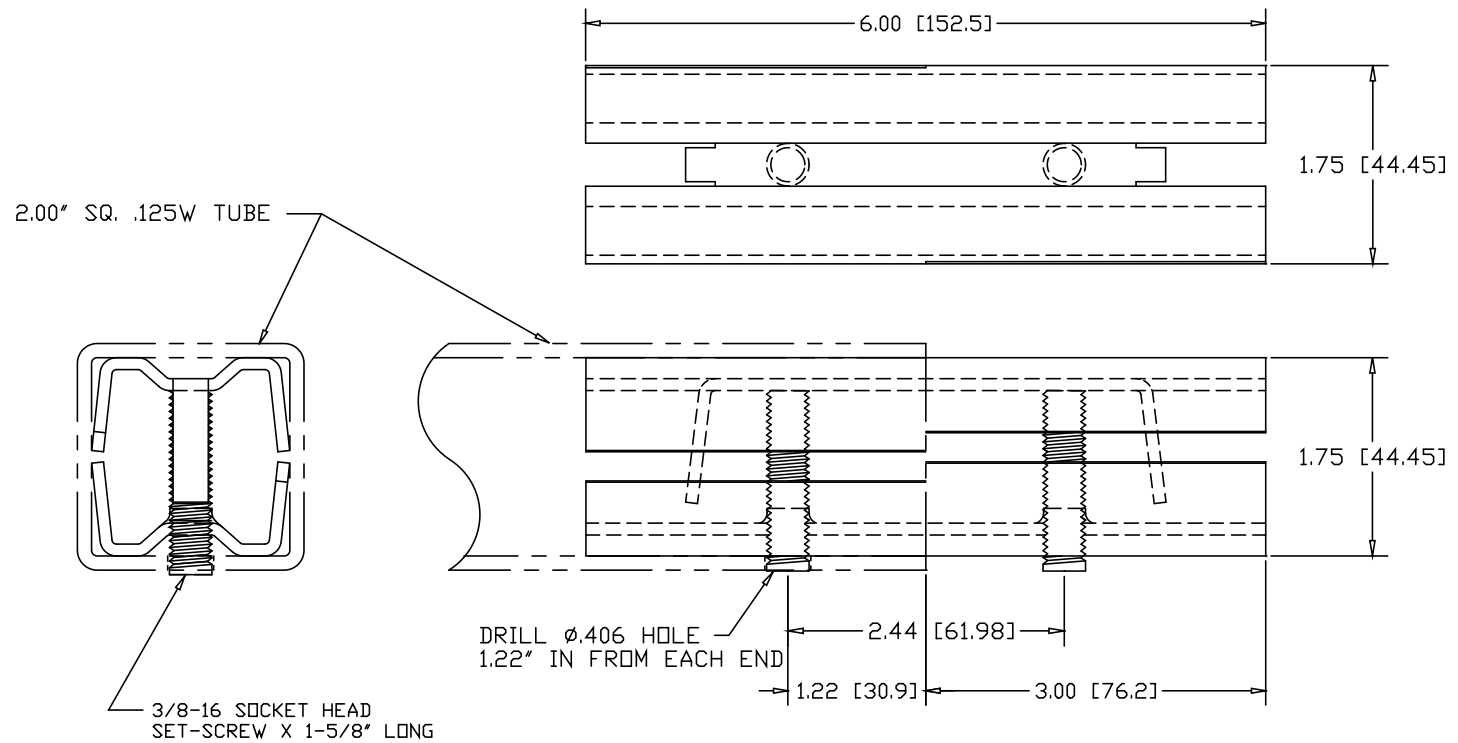

| REVISIONS | | | |
|-----------|-------------|------|----------|
| REV | DESCRIPTION | DATE | APPROVED |
| | | | |



INCHES [MILLIMETERS]

| ALTERNATE MATERIAL | PART NO. |
|---------------------------------|----------|
| 12 GA. STEEL HOT DIP GALVANIZED | G3373-3 |
| 12 GA. STEEL ZINC PLATED | PL3373-3 |
| .090 (3003) ALUMINUM ASTM B209 | 3377-3 |

| | | | |
|--|---|--------------------|-----------------|
| PART NAME 2.00" SQ. .125W TUBE DOUBLE-LOCK SPLICE-LOCK 6" LONG | | | |
| MATERIAL 12 GAUGE HRP&D STEEL ASTM A569 | | | |
| DATE 9/28/01 |  THE WAGNER COMPANIES R & B WAGNER, INC. AND J. G. BRAUN CO. | PART NUMBER 3373-3 | |
| DRAWN BY JAH | | SIZE A | WEIGHT 1.03 LBS |
| FINISH MILL | | | |