

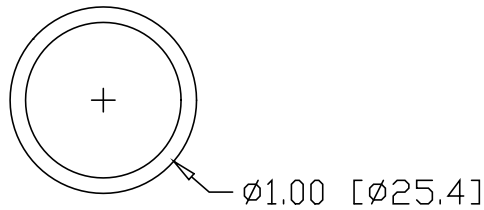

REV  
SH  
DWG NO 7803

REVISIONS			
REV	DESCRIPTION	DATE	APPROVED

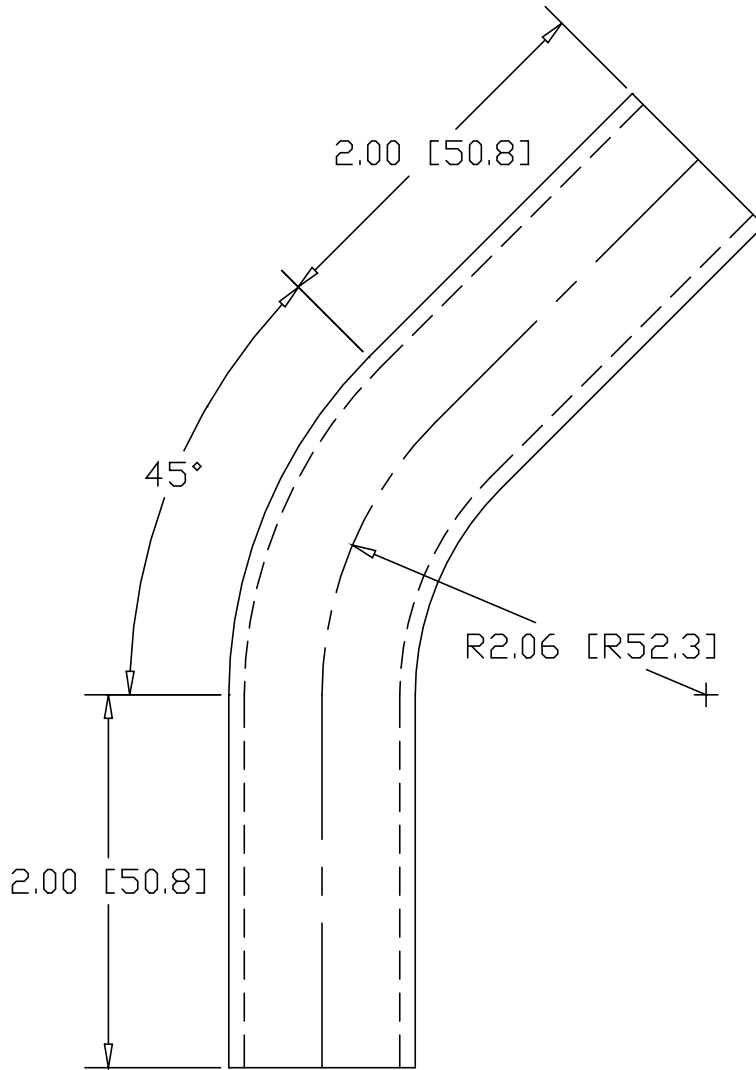

INCHES [MILLIMETERS]

ALTERNATE MATERIAL	PART NUMBER
1.00" OD X .125W (6061-T1) ALUMINUM TUBE	7819
1.00" OD X .083W (304) STAINLESS STEEL TUBE	7835

PART NAME 1.00" OD TUBE 45° ELL X 2.06" CLR W/(2) 2" TANGENTS			
MATERIAL 1.00" OD X .083W STEEL TUBE ASTM A513			
DATE 8/10/00		R & B WAGNER, INC.	
DRAWN BY RJF		SIZE A	WEIGHT .38 LBS
FINISH MILL			REV